

HEAVY DUTY

Kübler

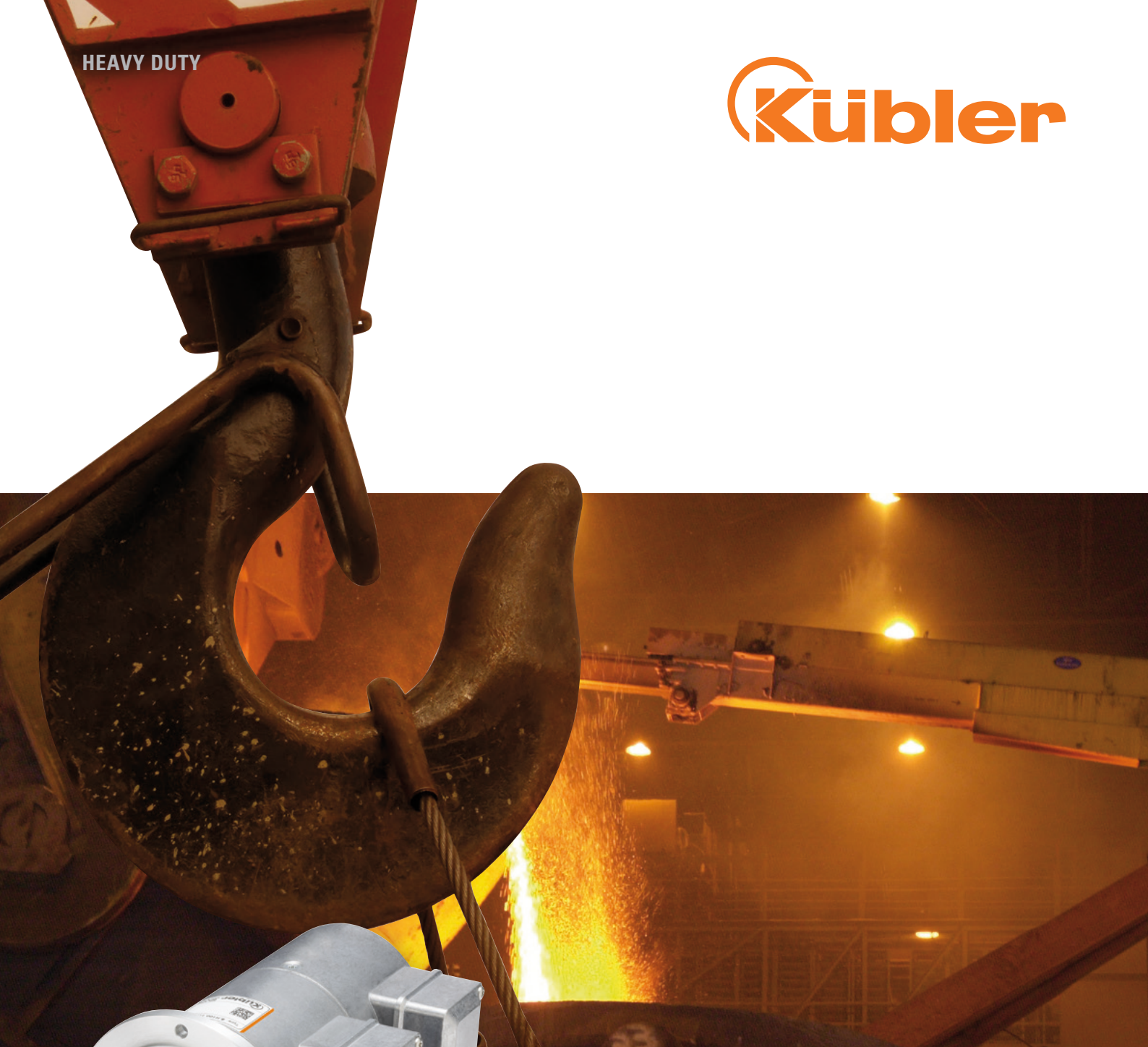

- Incremental Encoders
- Absolute Encoders
- Functional Safety
- Transmission Technology

■■■ *pulses for automation*

Solutions for Heavy Industry



Products and solutions that offer added value.

High plant availability. Heavy industry represents a very special challenge for sensors. External influences such as extreme temperatures, shocks and vibrations, dust and humidity make the reliable use of highly-accurate sensors difficult. Under such conditions, many sensors reach their limits.

Relying on years of experience and profound application knowledge in this sector, Kübler offers specially developed products and applications.

This wide product portfolio includes Sendix Heavy Duty encoders and robust compact encoders – equipped with particularly robust bearings, state-of-the-art housing technology and a wide range of communication interfaces. Only such features allow using these devices under extreme conditions.

Our system solutions for Functional Safety, consisting in encoders and safety modules, ensure safe interaction between man and machine.





Kübler Headquarters, Villingen-Schwenningen, Germany



Applications

- Speed measurement and positioning of rollers and drives in the steel industry P. 4
- Positioning and speed measurement for heavy cranes: Availability 24 hours a day P. 6



Products and Technologies

- Sendix Heavy Duty H100 / H120
 - Encoders for heavy industry P. 8
 - The product family P. 10
- Solutions for safety technology P. 12
- Technologies for heavy industry P. 14



Kübler Service

- Kübler Service for planning dependability P. 16
- Tailor-made solutions – Kübler Design System P. 17

The Kübler Group belongs today to the leading specialists worldwide in the fields of position and motion sensors, functional safety, counting and process technology and transmission technology. Founded in the year 1960 by Fritz Kübler, the family business is now led by the next generation of Gebhard and Lothar Kübler. Ten international group members and distributors in more than 50 countries offer local product know-how, service and advice throughout the world. Innovative product and sector solutions, as well as solutions for functional safety and a high level of service, are the reasons behind our global success. The strict focus on quality ensures the highest levels of reliability and a long service life for our products in the field. Over 450 dedicated people worldwide make this success possible and ensure that customers can continue to place their trust in our company.

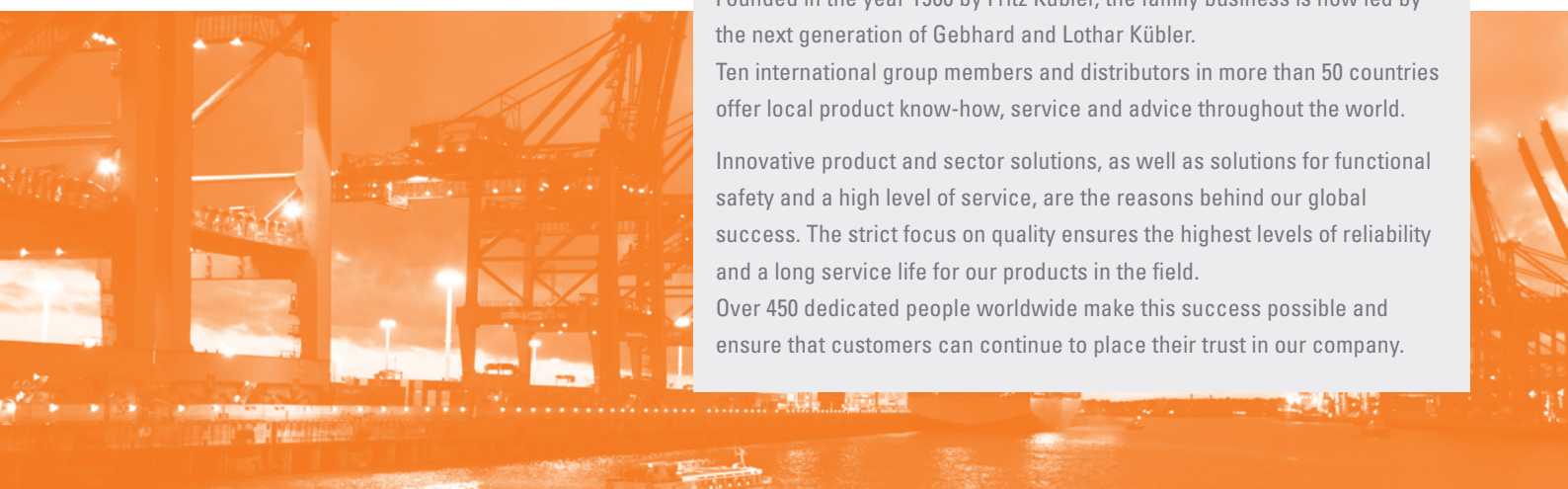

Speed measurement and positioning of rollers and drives in the steel industry

Position and motion sensors play an important role in steel plants. Even though they are exposed to harsh environmental conditions, the encoders must ensure an uninterrupted and safe process. Kübler encoders have given good service for many years in steel plants all over the world. Reliability is the main feature, especially for plants with very high operating costs.

1 Steel production

Positioning and speed regulation of cranes and trucks. Rugged sensors in very dusty environments with high mechanical requirements regarding shock and vibration resistance.

2 Steel casting

Rolling and cutting to length of the continuous strand. Use of encoders in extreme temperatures.

3 Hot rolling

Rugged speed regulation and accurate positioning of the rollers. Encoders in very hot and humid environments. Encoders suitable for rolling mills, shock-tested and with centrifugal switches to protect against overspeed.

4 Cold rolling

Highly dynamic speed regulation and accurate roller positioning. High speeds and strong vibration and shock stress. Positioning, as well as speed and hoist regulation of cranes.

5 Further processing

High-accuracy speed regulation in galvanizing plants. The encoders are exposed to humidity and many chemicals. Positioning, as well as speed and hoisting gear regulation of cranes.

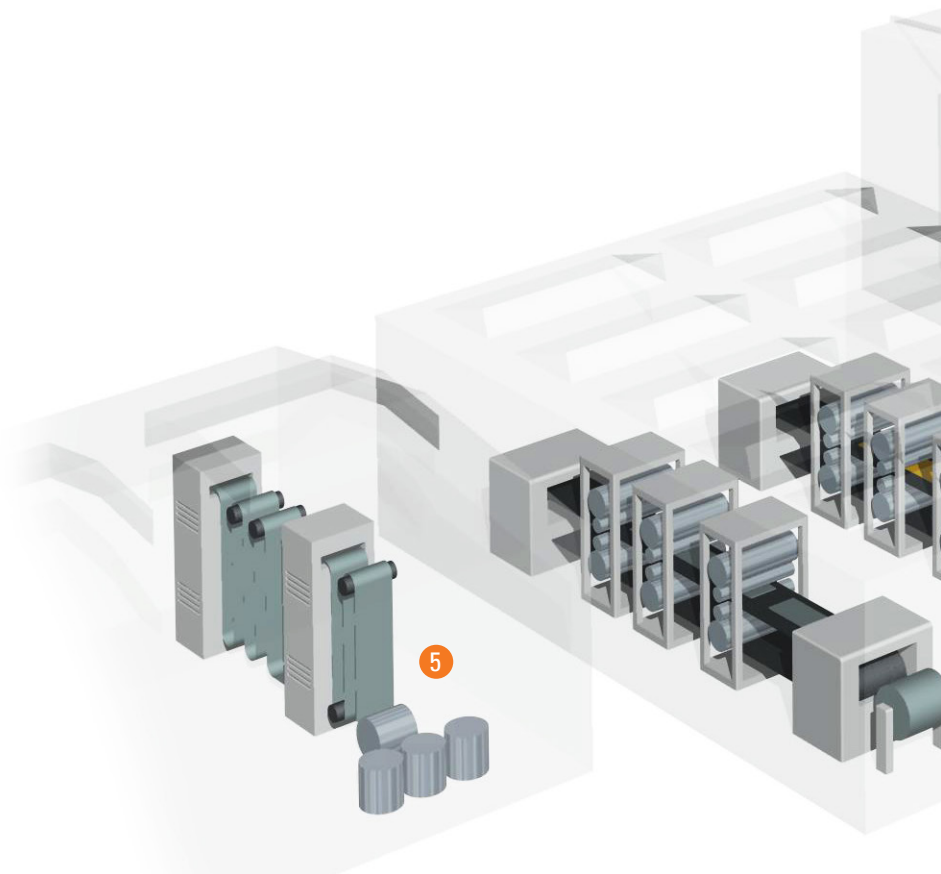

Sendix Heavy Duty H100 (shaft)

- Extremely high bearing load capacity thanks to HD-Safety-Lock™
- Seawater-resistant material
- Feather key fitting to the application
- Overspeed protection by means of mechanical speed switch
- Optional double encoder (twin encoder)

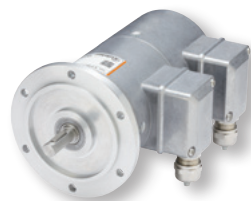

Sendix Heavy Duty H120 (hollow shaft)

- Bearing isolation up to 2,5 kV
- Extremely high resilience (IP66/67), high shock and vibration resistance
- Fastening arm on the flange or cover (flexible installation)
- Cable, plug-in connector, terminal box or optical fibre connection
- Up to 5000 ppr



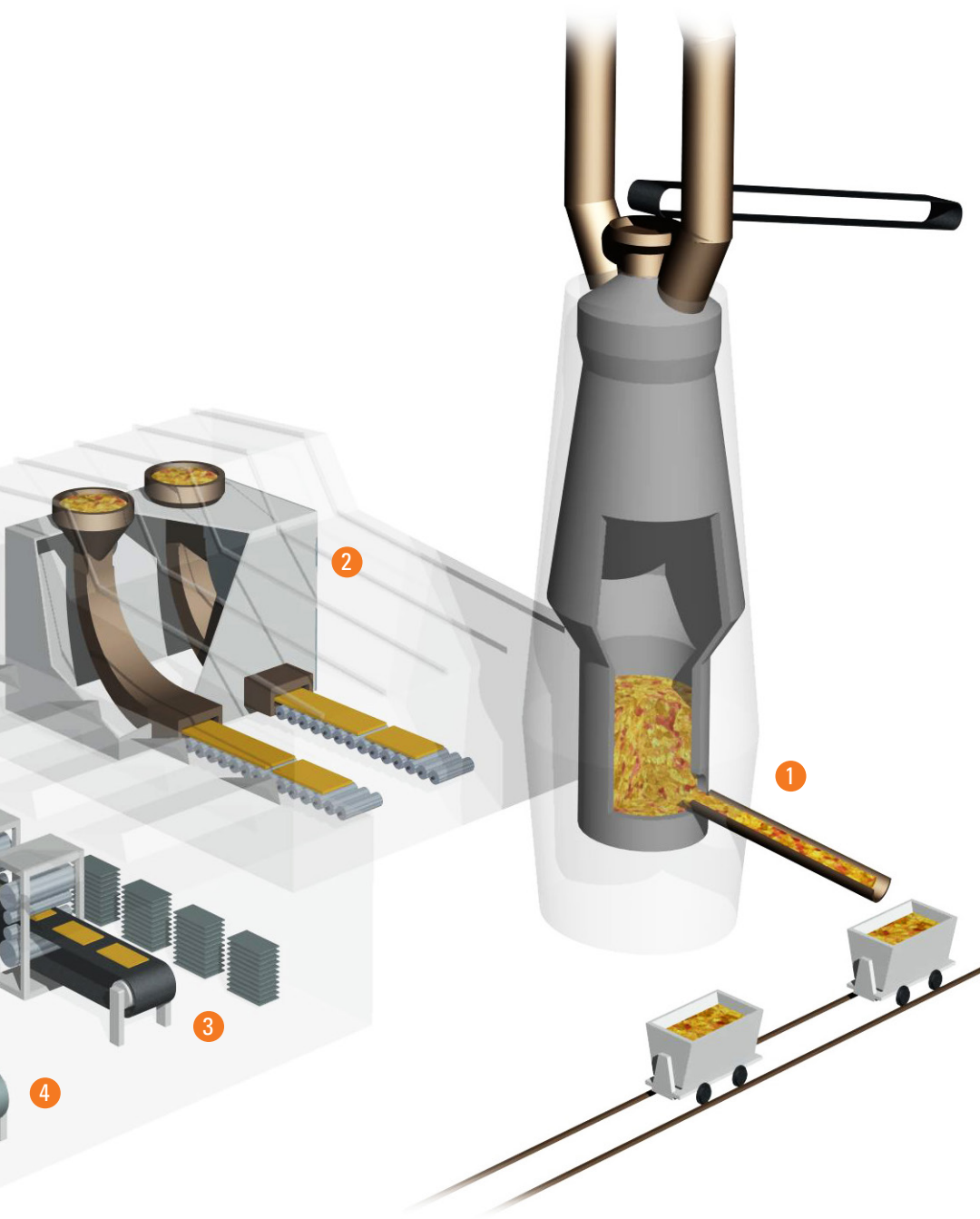

Optical fibre transmitter, receivers and cables

- For the transmission of incremental, SSI and EtherCAT signals
- No cable-related interference in the optical fibre cables, e.g. due to generators or inverters
- Safe transmission over distances up to 2000 m



5803/5823 high-temperature versions

- Incremental encoders with up to 5000 ppr
- Can be used from -20°C ... +110°C
- Insensitive to magnetic fields thanks to optical scanning
- Various connection possibilities for different application purposes



Sendix 5000 with Euro flange

- Compact and rugged incremental encoder
- Mounting compatible with the usual Heavy Duty encoders on the market thanks to the EURO flange
- Safety-Lock™ bearings construction
- Safe operation with humidity and dirt (IP67, -40°C ... +85°C)



Safety-M safety modules

- Gateways with standard and safe field bus / Industrial Ethernet interfaces
- Expansion modules for safe speed, position and motion monitoring
- I/O modules for connecting safe sensors. Up to 2 relays, 16 safe inputs and 8 standard outputs.

SIL3
Safety
PLe



Sendix SIL encoders

- Absolute singleturn and multi-turn encoders and incremental encoders for safety technology with SIL3 certification
- Interlocked bearings for a high degree of ruggedness, accuracy and a long service-life
- Insensitive to magnetic fields thanks to optical scanning

SIL3
Safety
PLe



PROFINET IO, PROFIBUS DP encoders

- Absolutely reliable operation under strong magnetic fields
- Fast and error-free connection thanks to M12 connector
- Max. resolution 28 bits, solid shaft or blind hollow shaft up to 15 mm
- Profinet with Isochronous Real-Time mode (IRT), Fast Start-Up (FSU) and Media Redundancy Protocol (MRP)



Positioning and speed measurement for heavy cranes: Availability 24 hours a day

Gantry cranes, container loading bridge cranes, stacking cranes ... the requirements for automation and safety are increasing.

Sendix encoders measure the position at the cable hoist, at the trolley, both on rails and on tyres, and at the spreader. Only these robust and safe measuring devices allow the automatic positioning of the containers.

The lifetime and availability of the sensors used is of the utmost importance for plants with high operating costs.

For decades, Kübler sensors have been delivering the highest performance for gantry cranes, in harbours and for underslung cranes on production lines or in steel plants.

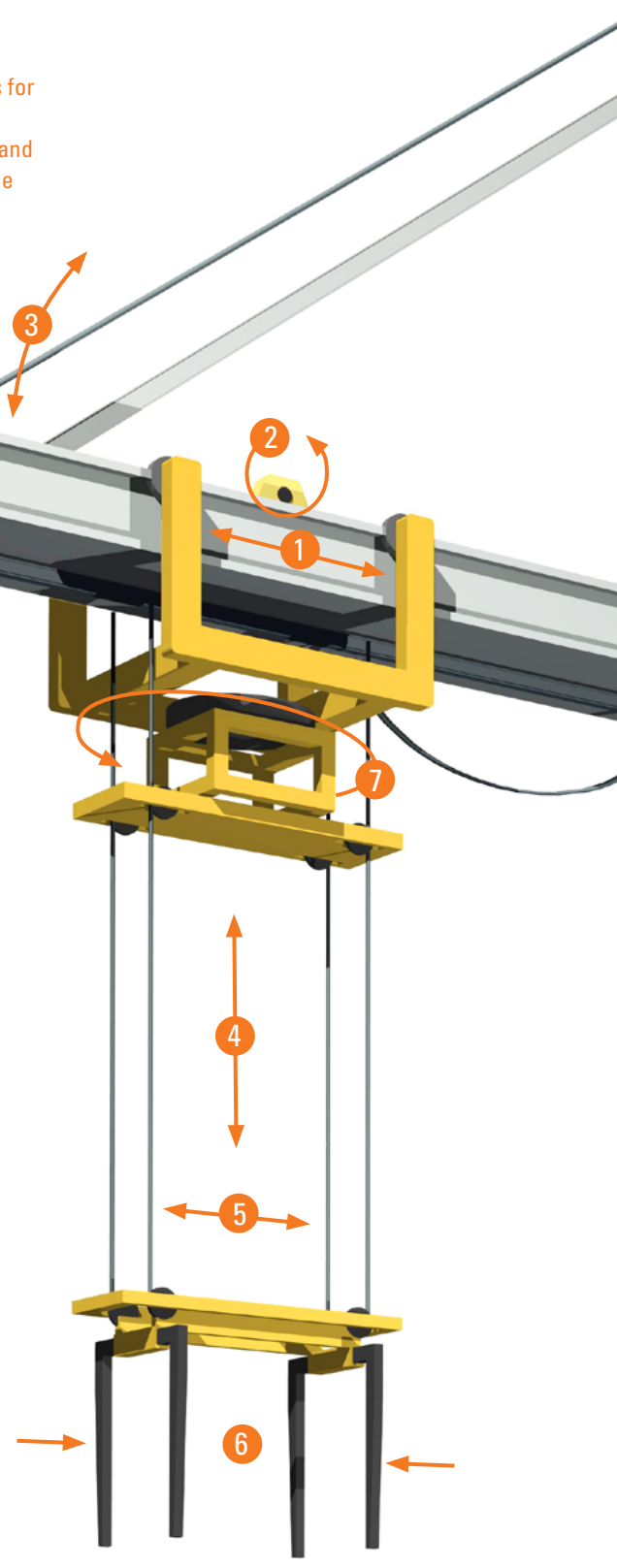

**1 Trolley position
Sendix M36R**

- Extremely robust bearing structure in Safety-Lockplus™ design
- Very high admissible shaft load and shock resistance
- Purely magnetic scanning
- Protection level IP66, IP67, IP69k
- V4A stainless steel variant
- Cost-efficient thanks to the Energy Harvesting technology
- Compact size, ø 42 mm



**2 Hoist speed
Sendix Heavy Duty H100**

- Extremely high bearing load capacity thanks to HD-Safety-Lock™
- Seawater-resistant material
- Feather key fitting to the application
- Overspeed protection by means of mechanical speed switch
- Optional double encoder (twin encoder)



You will find safety technology solutions on pages 12 / 13.

**8 Travel speed
Sendix 5000/5020**

- Compact and rugged incremental encoders
- Rugged Safety Lock™ bearing construction
- Safe operation with humidity and dirt (IP67, -40°C ... +90°C)



**2 Hoist speed
Sendix Heavy Duty H120**

- Bearing isolation up to 2,5 kV
- Extremely high resilience (IP66/67), high shock and vibration resistance
- Fastening arm on the flange or cover (flexible installation)
- Cable, plug-in connector, terminal box or optical fibre connection
- Up to 5000 ppr



**3 Boom angle / end position
Sendix M3658 CANopen**

- Compact singleturn encoder, diameter 36 mm
- Encapsulated electronics for outdoor applications (IP69k, -40°C ... +85°C)
- Magnetic scanning for a high shock and vibration resistance
- Status display
- Optional: seawater-resistant



**4 - 7 Spreader control
Sendix 58XX CANopen**

- Up to 16 bits singleturn and 12 bits multiturn resolution
- Safe operation with humidity and dirt
- High accuracy, insensitive to magnetic fields thanks to optical scanning
- Status display, reset button
- Optional: seawater-resistant



CANopen

Sendix Heavy Duty – encoders for heavy industry

Thanks to the special HD-Safety-Lock™ construction, the Sendix Heavy Duty encoders are ideally suited for applications in heavy industry, such as steel works and cranes.

Resistant materials, wide temperature ranges and a high protection level ensure they remain unaffected by the harshest environmental conditions.

Their innovative connection technology enables simple quick installation.

i Suitable for your Heavy Duty application

Safety-Lock™

- Mechanically interlocked bearings
- Large, extra-strong outer bearings
- Larger bearing span

Benefits:

Avoids premature damage or even encoder failure in the field.

Safety-Lock becomes HD-Safety- Lock

HD-Safety-Lock™ = Safety-Lock™ + additional engineering:

- + Floating bearing on the cover-side eliminates internal stress ¹⁾
- + Mechanically decoupled sensor unit ensures constant signal quality with large temperature fluctuations and other adverse environmental influences ¹⁾
- + Dual seals on the shaft-side – friction seal against humidity, labyrinth seal against dust and water jet ingress
- + Very large, highly-robust flange bearings
- + Even greater bearing clearance
- + Extremely robust flange mounting due to screw-on housing
- + Bearing design incorporates integrated isolation (isolating inserts not required), tested up to 2.5 kV for high running accuracy; metal to metal connection for slip free mounting ²⁾

Benefits:

The resistance against adverse environmental conditions is greatly increased – especially against high bearing loads and high temperatures.

	Safety-Lock™	HD-Safety-Lock™
Stability with vibration	+	++
Robustness against installation errors	++	++
Radial load	80 N	400 N
Axial load	40 N	300 N
Elimination of internal stresses	0	++
Constant signal quality with extended temperatures	+	++
Mechanical protection of the seal	0	++
Bearing isolation	0	++ ²⁾

1) for Sendix Heavy Duty H100 2) for Sendix Heavy Duty H120

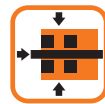

Thanks to the special HD-Safety-Lock™ hollow shaft bearing construction, an extremely high radial bearing load capacity is achieved (Sendix Heavy Duty H120)



Integrated bearing isolation up to 2.5 kV (Sendix Heavy Duty H120)

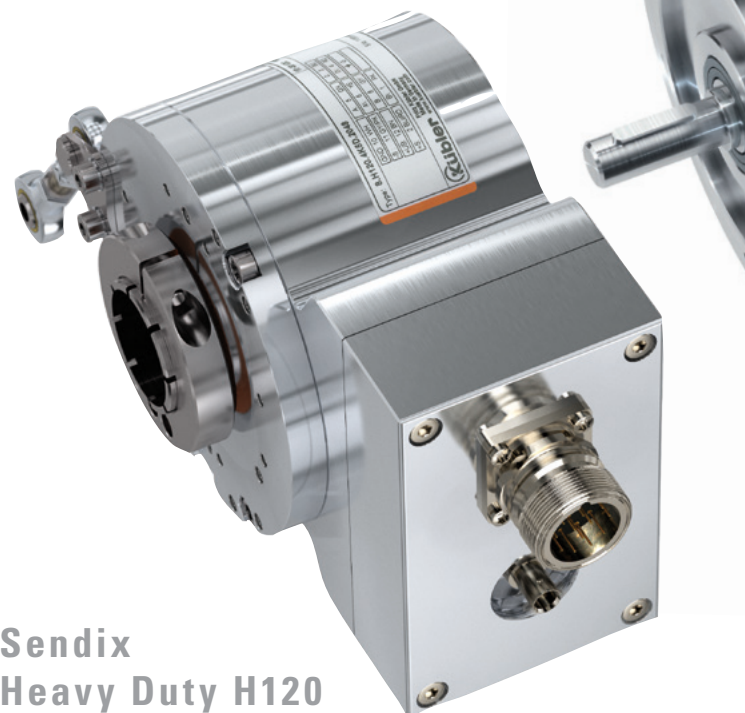

Sendix Heavy Duty H120



Through hollow shaft up to Ø 28 mm (Sendix Heavy Duty H120)



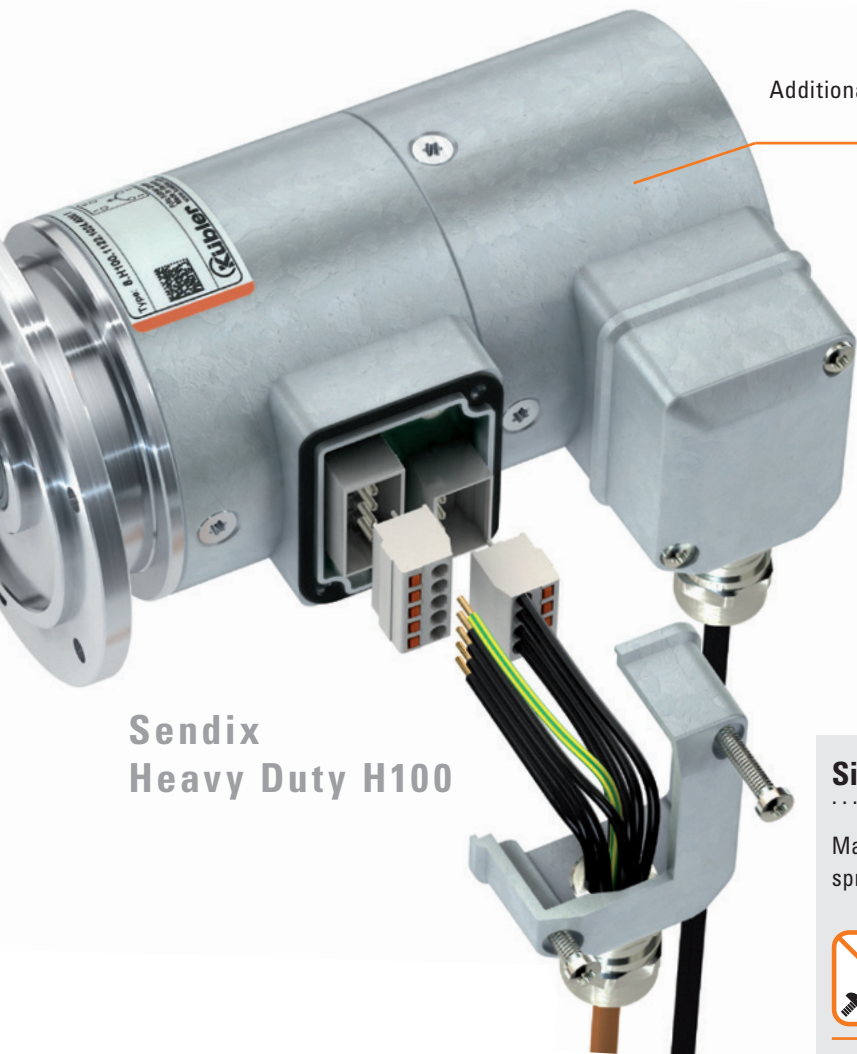
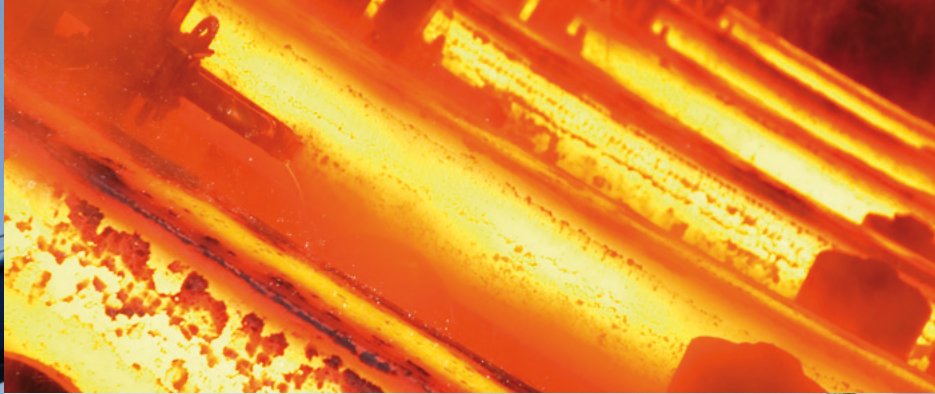

High level of protection against dust and humidity as a result of dual protection of the shaft (Sendix Heavy Duty H120)



Additional speed switch or second encoder

Sendix Heavy Duty H100

- 

Thanks to the special HD-Safety-Lock™ shaft bearing construction, an extremely high bearing load capacity is achieved (Sendix Heavy Duty H100)
- 

Feather key fitting ensures positive fitting to the application (Sendix Heavy Duty H100)

- 

High pulse rates up to 5000 ppr
- 

High shock (2000 m/s², 6 ms) and vibration resistance (150 m/s², 10 ... 2000 Hz)
- 

Seawater-resistant materials
- 



Suitable for outdoor use -40°+100°
- 

IP66/67
- 

Accurate and reliable optical sensor technology
- 

Simple quick installation

Maximum safety thanks to innovative connection technology with plug-in spring terminals in the terminal box, which is rotatable through 180°.



  	Sendix Heavy Duty with new terminal box connection technology	Standard terminal box connection technology
Simple, safe and fast installation	++	0
Quick connection of the cable to the spring terminal without the need for tools	++	not possible
Mounting of the encoder and electrical installation can be carried out separately	++	0
Preparation of the connection cable can be done in the workshop → facilitates installation in the field	++	not possible
Simplified installation where access is tight or difficult (no kinks in the cable)	++	+

Sendix Heavy Duty – the product family

The Sendix Heavy Duty devices are an extremely rugged incremental family of encoders that are offered in a wide variety of models: shaft, hollow shaft, with mechanical speed switch, as double encoder and with optical fibre module interface.

With their wide choice of connection options and fixing solutions, the encoders of the Sendix Heavy Duty family can be used in numerous application areas.

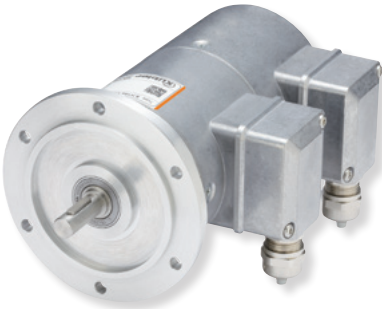
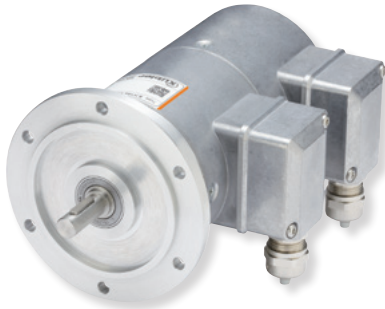
The Sendix Heavy Duty family at a glance ...

Product variants / Functionality			
Sendix Heavy Duty H100	 Incremental shaft encoder	 Incremental shaft encoder with mechanical speed switch	 Incremental double shaft encoder
	<hr/>		
	Sendix Heavy Duty H120	 Incremental hollow shaft encoder	 Incremental hollow shaft encoder for connection to optical fibre modules



... a wide variety of versions for every installation situation

Connection options

Terminal box connection with plug-in spring terminal connectors (connection cover rotatable through 180°)



Cable connection for space-saving mounting – the economical solution



Plug-in connectors for fast and error-free connection of the encoder



Terminal box connection with plug-in spring terminal connectors (connection cover rotatable through 180°)



Optical fibre connection highest degree of security, even over very long distances

Fixing solutions

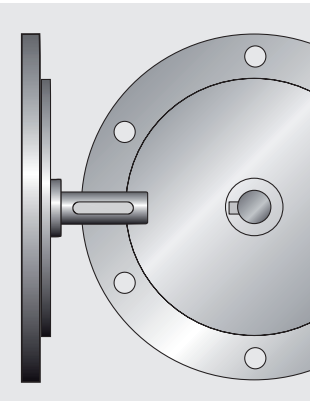

EURO RE0444 flange
Shaft \varnothing 11 x 30 mm with feather key fitting

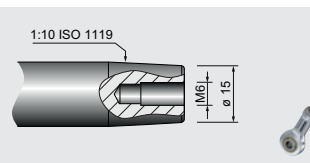

Tapered hollow shaft 1:10, central fixing

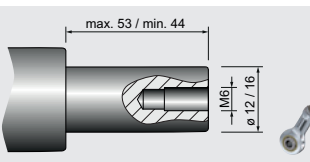

Cylindrical hollow shaft
 \varnothing 12 mm / 16 mm with central fixing

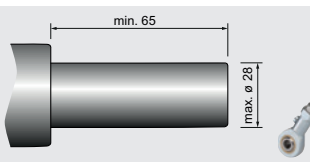

Through hollow shaft \varnothing 16 ... 28 mm

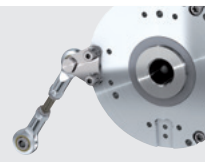
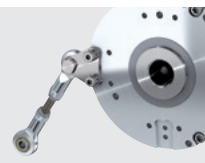

Fastening arm
70, 100 or 150 mm

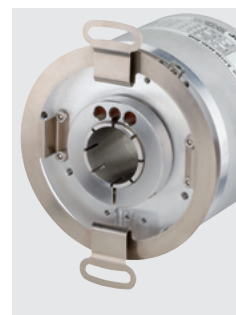

Stator coupling, double-winged

Sendix Heavy Duty H100

Sendix Heavy Duty H120

Solutions for safety technology

Safe single components alone do not fully ensure a safe global application. Only the optimal interaction between safety sensors and safety monitoring modules offers reliable solutions, which will meet the necessary safety requirements.

The optimal combination of Kübler's Safety-M modules and Sendix SIL encoders allows the easy implementation of a safe drive monitoring system.

Kübler safety technology for crane facilities

Crane facilities become increasingly large and efficient. Higher loads and working speeds lead to ever more demanding safety requirements. The time slots for loading and unloading are small and working pressure is high - increasing the risk of making errors or overlooking dangers. Without suitable protective equipment, cranes may collide, loads may swing or people in safe working areas may be overlooked.

A comprehensive family of safe encoders, safety controls, and helpful service packages

Safety modules

- Safety-M modular with field bus and Industrial Ethernet protocols, with safe protocols such as PROFIsafe, with safe cross communication
- Axis expansion modules for speed and position
- I/O expansion modules

Sendix SIL encoders

- Incremental SIL encoders
- Absolute SIL encoders – singleturn and multiturn

Safety Services – service packages

- Risk Assessment
- Safety Concept
- Start-up / Validation
- Safety Retrofit



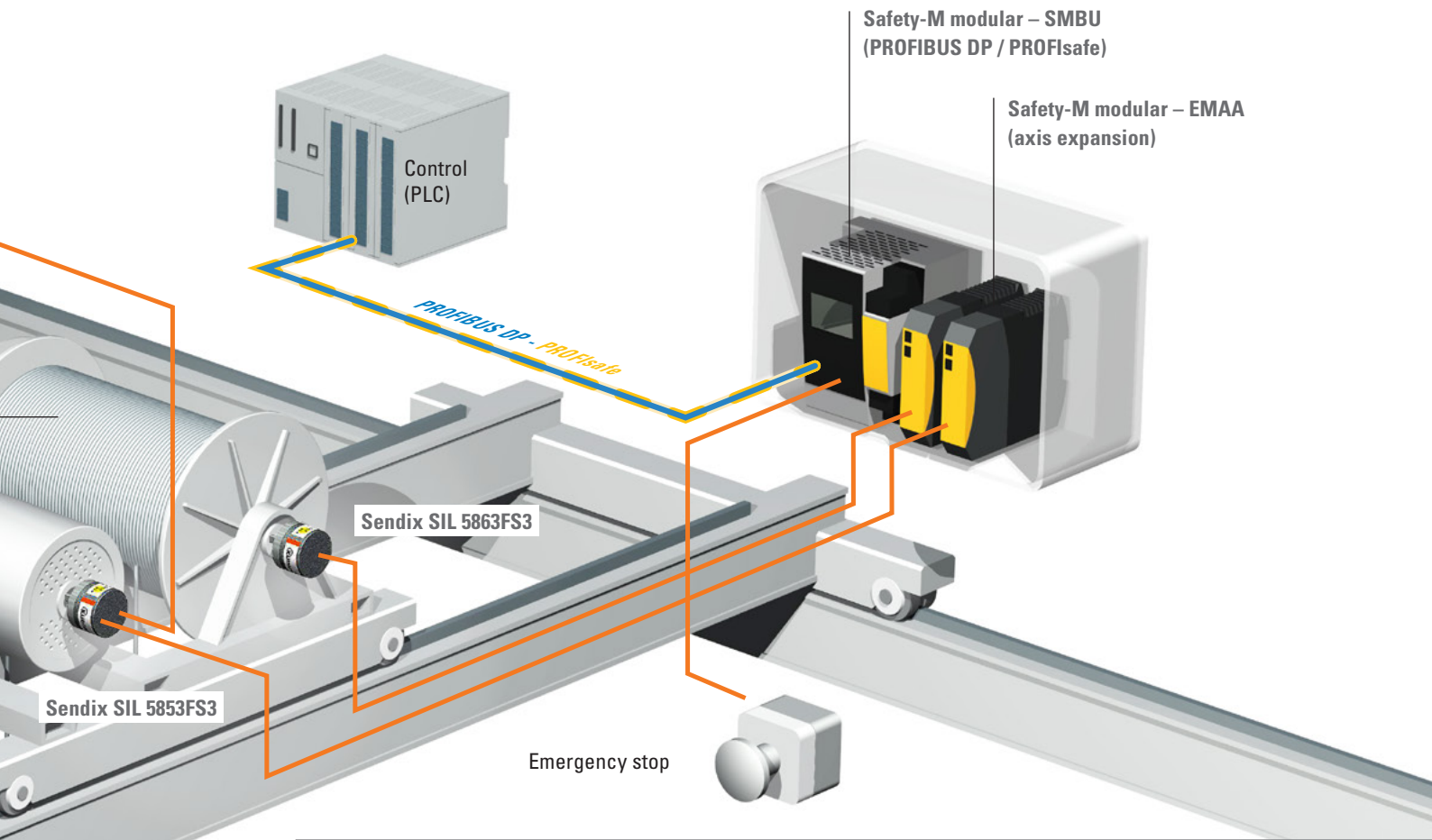

Example overhead crane / Metal production

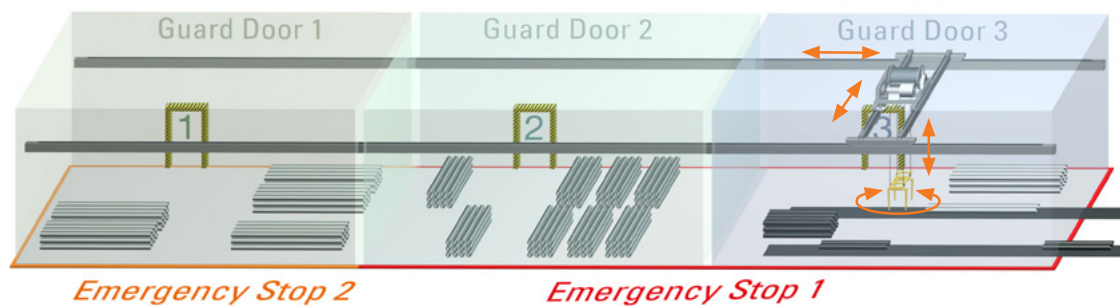

Requirements:

- Three separate access controls.
- Two independent emergency stop circuits.
- Individual blocking of storage areas for the crane.
- Safe speed and position monitoring for the trolley and outrigger.
- Safe end position and overspeed monitoring for the hoist.
- Prevention of oblique position of the travel axis.
- Saving limit switches.

We offer the solution!

- Robust solutions for single cells that can be or are to be coupled together.
 - Safe cross-communication among cells.
 - Integrated gateways for all common field bus systems (CANopen, PROFIBUS DP, PROFINET IO, EtherCAT, EtherNet/IP).
 - Safe field buses such as e.g. PROFIsafe.
 - AS-I Master for modularity.
- High plant availability – faster and easier components replacement (time is money).
- Easy programming and commissioning – as generally there are no software or automation control specialists available on site.



Technologies for heavy industry

Innovations from tradition. Kübler products benefit from more than 50 years experience in automation engineering. Over the years they have undergone ongoing development and been optimized for use in heavy industry.

Small details make a big difference. Our products feature many intelligent, high-quality extras, which offer our customers decisive advantages, whilst at the same time making a significant contribution to the high availability and safety of the machines.

Optical encoder technology



100 percent resistant to magnetic fields – extremely compact design. Even strong magnetic fields, as occur in the vicinity of brakes or drive motors, pose no problems for the sensor technology of optical encoders.

The technology dispenses with any components that may be susceptible to magnetic influences and allows for high scanning rates. The multiturn gear module – developed from special materials – is effective thanks to its double bearing layer and the specially developed gear teeth, resistant against wear, and can be used for high speeds up to 9000 min⁻¹. As a result of the proven drive, the encoder has no need of a battery to store the number of revolutions.

Insensitive to interference: OptoASICs



The resistant Kübler OptoASIC technology offers a very high integration density of components.

This means that, on the one hand, the reliability in the application can be increased significantly, and on the other hand the technology demonstrates quality EMC characteristics and shock resistance.

Wide temperature range



High heat resistance – combined with high rotational speeds – make the Kübler Sendix encoders the optimal solution for all applications in a high temperature environment.

Also the seals, cables and connectors used withstand extreme temperatures.

Shaft isolation



Even well-earthed machine housings and rotors of generators and large motors carry a shaft current on the rotor. The equipotential bonding from the rotor to the stator via the encoder bearings leads to spark erosion and can damage the encoder. This can be remedied by isolating the encoder bearings. Isolating inserts can be used with all Sendix compact encoders. The Sendix Heavy Duty H120, for example, has a fully integrated and isolated bearing construction and is tested to a breakdown voltage of 2.5 kV.

Robust bearings



Kübler encoders boast a very sturdy and robust bearing construction, brought together under the term Safety-Lock™. Encoders with Safety-Lock™ have positive interlocked bearings with a large bearing span and special mounting technology. This means they are able to tolerate installation errors as well as large shaft loads, as can occur as a result of temperature expansion or vibration.

A further development of this technology is employed in the Sendix Heavy-Duty encoders (HD-Safety-Lock™).

Encoders are available for use in drive engineering that will operate reliably at speeds of up to 12,000 min⁻¹.



High protection / seawater resistant



A high protection level is achieved as a result of the integrated radial shaft seal. This, together with the wide temperature range and the bearing technology, ensures outdoor use is possible without problems. Many versions of the Sendix family of devices have now been tested and certified to IEC 68-2-11 for resistance to the effects of salt-spray over a period of up to 672 hours – the highest test level. The high certification level for the Sendix encoders attests a high level of corrosion resistance.

Safety-Lockplus™



Interlocked bearings, a large bearing span and extra-strong external bearings ensure stability in case of vibrations and robustness against installation errors. This prevents machine standstill and repair work. The proven Safety-Lock™ construction includes additionally a mechanically protected shaft seal.

Hardened down to the last detail



The durable construction that comes as standard, permits high shock and vibration values; these are both tested and certified. In the steel industry, as in crane installations, these values are very important. Dual seal protection on the shaft side, for example with the Sendix Heavy Duty H120, offers increased protection against dust and humidity for harsh operating conditions.

Approvals

All encoders from the Kübler company carry the CE mark and are tested for electromagnetic compatibility and immunity to interference. As an option, our products can be UL approved. Many of our products are available on request with EX approval for explosion protection zones 2 and 22 or as product variants for zones 1 and 21. Certified Functional Safety: this permits simple implementation of applications for the protection of personnel. Kübler is active worldwide and considers the protection of the environment as a corporate obligation. Our product range complies with the RoHS directive.





Presales

Kübler – the service specialists for every industrial sector and application
– supplying complete integrated solutions – globally on your doorstep

Sample Service – Fast delivery
of customised versions

Selection tool

Kübler website: Product Finder

Delivery Service: 10 by 10,

48 h Express and Repair Service



Kübler Service for Planning Dependability

Fast, reliable service and professional advice have top priority at Kübler. We are globally on your doorstep in 8 service and application centres and offer our customers planning dependability. Our processes and services are certified and are constantly being improved.

Technical Hotline



Our Hotline will answer your technical questions
Mon-Fri within normal working hours:

+49 7720 3903-952

Local support:

Kübler Germany	+49 7720 3903-952
Kübler China	+86 10 8471 0818
Kübler France	+33 3 89 53 45 45
Kübler India	+91 8600 147 280
Kübler Italy	+39 0 26 42 33 45
Kübler Poland	+48 6 18 49 99 02
Kübler Turkey	+90 216 999 9791
Kübler USA	+1 855 583 2537

10 by 10



With our 10 by 10 Service we will manufacture and deliver 10 encoders (catalogue products so marked) within 10 working days – 365 days a year - with the exception of 24th Dec. until 2nd Jan.

The benefits to you: Easier to order, the delivery can be calculated, flexibility for small production batches.

48 h Express Service



Short delivery times, a high level of on-time delivery, guaranteed quality and enthusiastic, service-oriented employees – these are what our customers can depend on.

We can process your order within 48 hours; we can ship stock items the same day.

Sample and Repair Service



The Kübler Service Centre can quickly manufacture special, customised versions within a short space of time. We are happy to help you with the practicalities of using our products – at your location if desired.

We can carry out repairs within a maximum of 5 working days.



Kübler online – www.kuebler.com

- Up-to-date product and company information
- Product finder – the selection tool that helps you finding quickly the suitable product
- Download service for catalogues, brochures, operating instructions, software and CAD data



Service Excellence provided by Kübler application specialists for target sectors

Product security – replacement models at the end of the product life-cycle

Aftersales

Service Centres, globally on your doorstep:
Advice, analysis, support during installation in over 50 countries

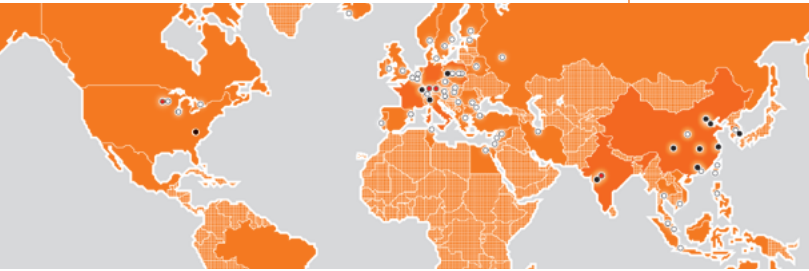

« We were able to considerably reduce our average delivery time and I can confirm that delivery schedules were always adhered to. Technical support is very professional, efficient and not at all bureaucratic. »

Purchasing Manager, German Producer of Geared Motors

Tailor-made Solutions – Kübler Design System

« With the KDS method our customers receive a lasting solution to lowering costs, reducing the number of models available or eliminating quality deficiencies. With KDS we develop product and engineering solutions together. The method stands out because of its structured process; this delivers innovation through experience and cooperation with the customer. »

Gebhard and Lothar Kübler, Managing Directors Kübler GmbH

The Kübler Design System – satisfying customer demands

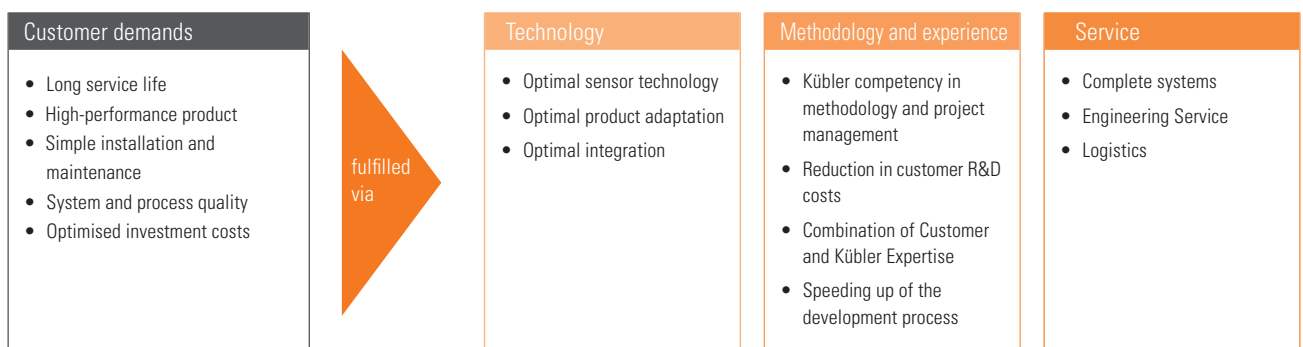

The 4 phases of the Kübler Design System

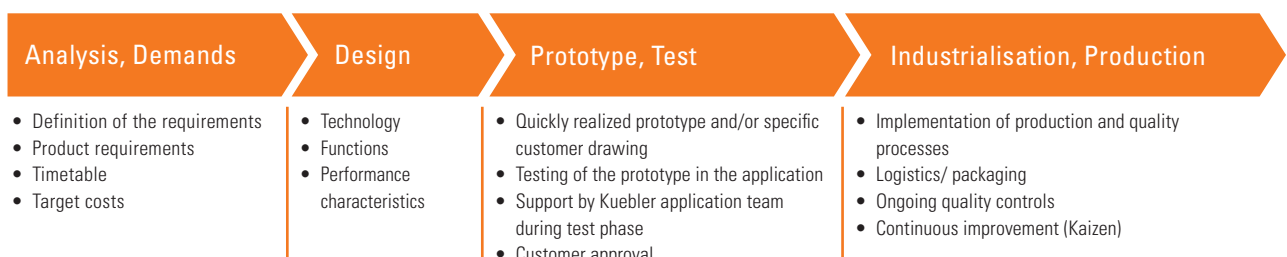

References

What is crucial is how products withstand the endurance test in practice!

Here, every day, Kübler encoders demonstrate their high quality standards - and this applies to every area of application.

Many international companies have confidence in our solutions for heavy industry.

These companies include the following:

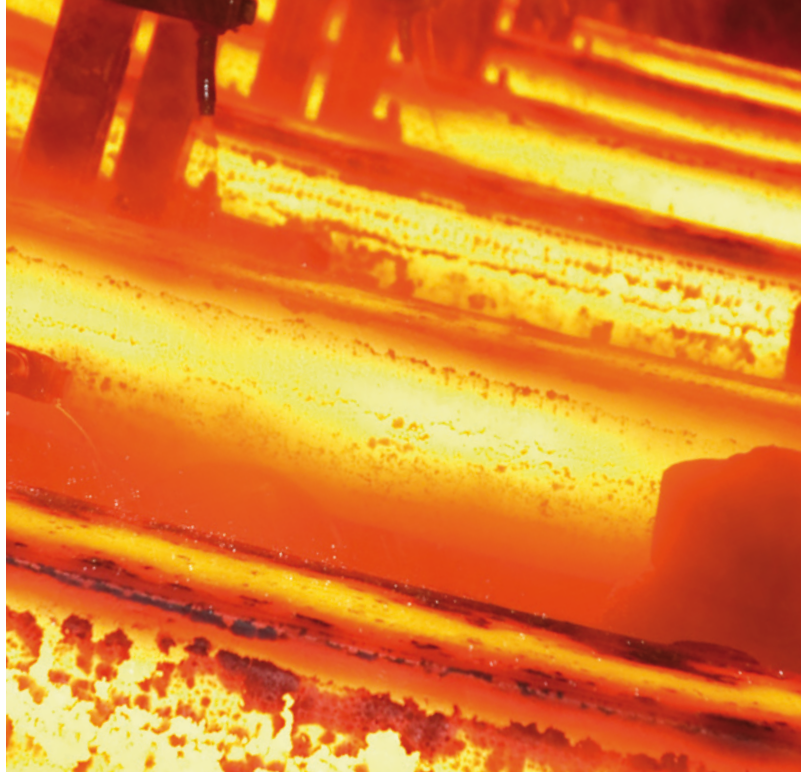

SMS Meer GmbH - Germany

**SMS
MEER**

SMS group

Sendix 5868 Profibus absolute encoders for format setting in long-product and semi-product rolling mills

BAO Steel - China

 **BAOSTEEL**

Sendix 5020 incremental encoder for motor speed and Sendix 5888 Profibus encoder for roller position in cold rolling mills

Demag Cranes and Components - Germany

DEMAG
Cranes & Components

Sendix 5000 incremental encoders for motor speed measurement

TATA Steel - India

TATA STEEL

A02H Heavy Duty incremental encoders for vessel tilt drive

AG der Dillinger Hüttenwerke - Germany

 **DILLINGER HÜTTE**

A02H incremental encoder and optical fibre modules for roller speed measurement

Wuhan Iron and Steel Corp. – China

 **武钢股份**

Kübler Sendix 5020 incremental encoder user for motor speed measurement in steel smelting shop



Heavy Duty 2015

www.kuebler.com



www.kuebler.com/heavy_duty

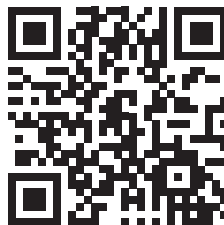

Kübler Group
Fritz Kübler GmbH
Schubertstrasse 47
D-78054 Villingen-Schwenningen
Germany
Phone +49 7720 3903-0
Fax +49 7720 21564
info@kuebler.com
www.kuebler.com

R.100.809 05 250 15 ES

■■■ *pulses for automation*