

- Encoders
- Bearingless Encoders
- Motor Feedback Systems
- Linear Measuring Technology

Kübler encoders and motors – a perfect pairing.

Kübler is strongly rooted in drive technology and has been developing appropriate sensor solutions for speed and position detection for different electric drives for decades. Renowned drive manufacturers trust our encoders, bearingless encoders and motor feedback systems. All of them are based on the highest quality, robustness and sustainable technologies.

Combined with the large and flexible selection of mounting and installation solutions, Kübler encoders are the ideal solution for any conceivable task in drive technology. We are also happy to take on individual challenges and implement modifications and special solutions quickly and easily.

When will you choose Kübler?



Contents

Technologies for Drive Technology	4
Internal Encoders for Drive Technology	
Motor Feedback Systems for servo motors	6
Internal encoders for asynchronous motors	8
External Encoders for Drive Technology	
External encoders for asynchronous motors	10
External encoders for large motors / generators	14
External encoders for stepper motors	16
Magnetic length measuring systems for linear motors	18
Encoders for Elevator Technology	20
Encoders for Explosion Hazardous Applications	22
Encoders for Functional Safety	24
Electrical Interfaces	
Overview electrical interfaces	26
Mechanical Interface and Accessories	30
Customized Solutions	32
Company	
Product portfolio – Made in Germany	34
Kübler Service for worldwide planning reliability	35

Technologies for drive technology

Innovations from tradition. Kübler products benefit from 55 years experience in automation technology. Over time they have been further developed for use in drive engineering. Small details make a big difference. Our products feature many intelligent top-quality extras and offer our customers key benefits. In doing so, they make a significant contribution to the high availability and safety of the machines.

Optical encoder technology



Magnetic field-resistant, even strong magnetic fields, as they are generated in the environment of brakes or geared motors, are not a problem for optical encoders.



This technology does not use any components sensitive to magnetic fields and allows high sampling rates.



Thanks to its first stage mounted on two ball bearings and to the specifically developed special toothing, the multiturn gear module acts durably against wear and can be used for high speeds up to 9000 rpm.

Electrical interfaces



Kübler encoders boast a wide variety of interfaces. Along with incremental interfaces such as TTL / HTL and SinCos there are also absolute interfaces such as SSI, BiSS and BiSS Safety.



The outputs and supply voltage are short-circuit protected.



Insensitive to interference: OptoASICs



The resistant Kübler OptoASIC technology is characterized by good EMC features, high shock resistance and particular reliability in the application.

Wide temperature range



High heat resistance – combined with high rotational speeds – make the Kübler Sendix encoders the optimal solution for all applications in a high temperature environment.

Intelligent Scan Technology™



The Intelligent Scan Technology™ is a technology patented by Kübler that allows realizing electronically the multiturn feature with an optical encoder. This technology is based on the many years of experience in the area of 100 % magnetically insensitive OptoASICs. The result: a very high resolution reaching 41 bits.

Approvals

All encoders from the Kübler company carry the CE mark and are tested for electromagnetic compatibility and immunity to interference. As an option, our products can be UL approved.

Products with Ex approval and products certified for Functional Safety complete Kübler's products range.



Robust bearings



Kübler encoders boast a very sturdy and robust bearing construction, brought together under the term Safety-Lock™.



Encoders with Safety-Lock™ have positive interlocked bearings with a large bearing span and special mounting technology. This means they are able to tolerate installation errors as well as large shaft loads, as can occur as a result of temperature expansion or vibration.

Housing geometry



The compact design dimensions specially conceived for drive engineering as well as the very compact connector solution permit optimal integration on or under fan cowls.



The version with tangential cable outlet is ideal for tight mounting spaces and allows fast and simple installation.



Hardened down to the last detail



The durable construction that comes as standard, permits high shock and vibration values; these are both tested and certified. The values are extremely important in drive engineering, as the potential applications for the motors are highly diverse.



Simple / fast installation



Innovative connection technology with plug-in spring terminal connectors allows for fast, safe installation without tools. Maximum connection safety with minimal connection times.



Shaft isolation



Even well-earthed machine housings and rotors of generators and large motors carry a shaft current on the rotor.

The equipotential bonding from the rotor to the stator via the encoder bearings leads to spark erosion and can damage the encoder. This can be remedied by isolating the encoder bearings. Isolating inserts can be used with all Sendix compact encoders.

High protection level / seawater durable



A high protection level is achieved as a result of the integrated radial shaft seal. This, together with the wide temperature range and the bearing technology, ensures outdoor use is possible without problems.



Many versions of the Sendix family of devices have now been tested and certified to IEC 68-2-11 for resistance to the effects of salt-spray over a period of up to 672 hours – the highest test level. The high certification level for the Sendix encoders attests a high level of corrosion resistance.

Motor Feedback Systems for servo motors

Synchronous servo motors are predestined for all applications requiring accuracy and dynamics. They thus suit optimally for converter operation.

Motor Feedback Systems are essential components in drive systems to ensure optimal control characteristics - in particular for dynamic axes, smooth speed controls and for positioning accuracy. They thus make a significant contribution to the performance of the whole plant.

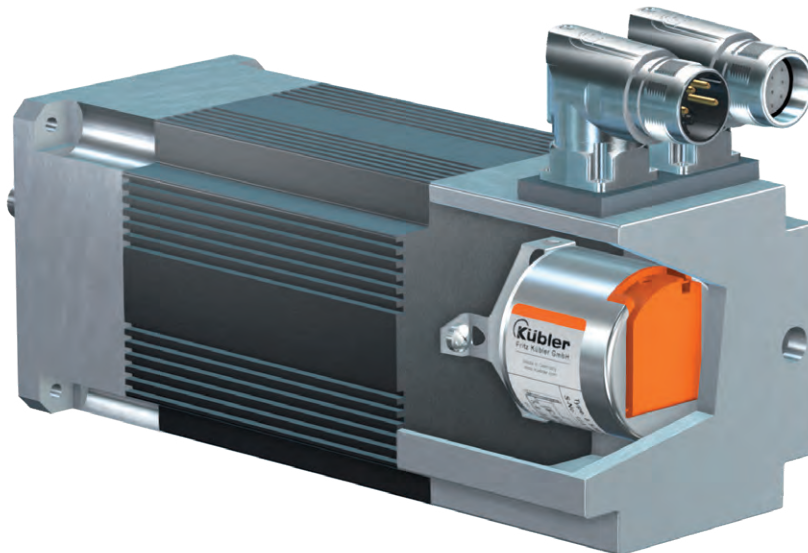

Application specific requirements

Installation	The small size of the motors means every millimeter counts. It is therefore essential to use compact yet powerful sensors.
Commutation	To ensure effective control of the servo motors, it is important to have precise information on the position of the rotor. This can be provided via single or multiturn information.
Temperature range	Above all, the intrinsic heating of the powerful synchronous motors entails high ambient temperatures. As the sensors are highly integrated in these drives, encoders are more directly exposed to high temperatures than is the case with other motors.
Accuracy	To ensure good control, especially for large numbers of poles, the encoders must have a high degree of accuracy.

Motor Feedback Systems for servo motors

Servo motors are characterized by their high dynamics and performance. These features are only reached if the servo converter can control the motor optimally. This requires high-performance sensors such as Kübler's Motor Feedback Systems.

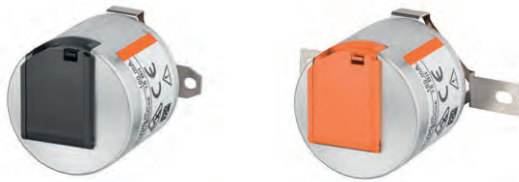

	Sendix S3674 singleturn	Sendix S3684 multiturn
General information	Motor Feedback System for the medium and high performance range	Motor Feedback System for the medium and high performance range
Functional Safety	SIL2	SIL2
Mechanical interface	Hub shaft \varnothing 8 mm Tapered shaft \varnothing 8 mm	Hub shaft \varnothing 8 mm Tapered shaft \varnothing 8 mm
Electrical interface	RS485 + SinCos (Hiperface [®] ¹⁾ compatible) BiSS + SinCos BiSS fully digital	RS485 + SinCos (Hiperface [®] ¹⁾ compatible) BiSS + SinCos BiSS fully digital
Size	\varnothing 36 mm	\varnothing 36 mm
Resolution SinCos	1024 or 2048 ppr	1024 or 2048 ppr
Resolution max.	23 bit singleturn	23 bit singleturn + 12 bit multiturn
Speed max.	12000 min ⁻¹	12000 min ⁻¹
Temperature range	-30°C ... +120°C	-30°C ... +120°C
Power supply	5 V DC 7 ... 30 V DC	5 V DC 7 ... 30 V DC

¹⁾ Hiperface[®] is a registered trademark of Sick Stegmann GmbH.

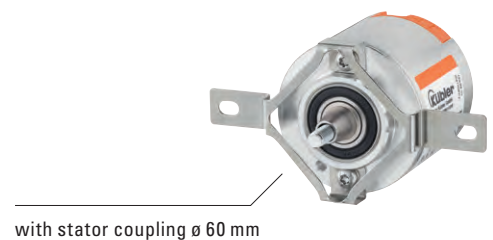
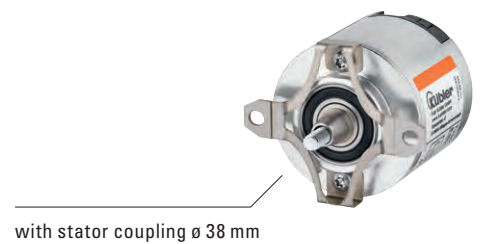

Internal encoders for asynchronous motors

Asynchronous motors are increasingly used in applications where the available space is limited. In response to this requirement, drives are becoming ever more compact.

To reduce the length, Kübler provides magnetic, bearingless encoders, which can also be integrated customer specifically in the motor. A scope of delivery tailored to customer requirements and comprising sensor head, magnetic ring and shielding (against magnetic effects from the brake) is provided for such purpose.

This modular system consisting of optimally coordinated components allows Kübler to provide solutions for all motor sizes with minimum variance.



+ Your benefit

- 100% integration in the motor
- Slim motor design
- High assembly tolerance
- Accurate control
- Ready for Smart Motor

Interference fields – no problem. Kübler shielding technology.

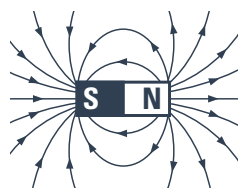

Electromagnetically actuated brakes generate strong magnetic fields, which make the operation of a bearingless magnetic encoder in their immediate proximity impossible. A shielding method calculated by FEM manages to shield the interference field of the brake at 100 % in the area of the sensor.

Bearingless encoders as 100 % integration in asynchronous motors

Kübler offers an innovative solution here. It has made the asynchronous motor – the world's most common electrical drive – even smarter and more compact. Thanks to the individually integrated magnetic sensor solution, the dimensions of an asynchronous motor are now significantly reduced – this saving space and costs above all. Smart technology will also make these motors fit for the future. Evaluated data for condition monitoring and predictive maintenance are available.



	RLI20, RLI50	RIL201, RIL501
Electrical interface	Push-pull, RS422 SinCos	Push-pull, RS422 SinCos
Sensor head	Size 40 x 25 mm	Adapted to customer application
Magnetic ring	Ring diameter depends on pulse rates	Adapted to customer application
Resolution max.	On request (resolution depends on ring diameter)	On request (resolution depends on ring diameter)
Speed max.	12000 min ⁻¹	On request (customer-specific up to max. 12000 min ⁻¹)
Temperature range	-20°C ... +80°C	typ. -30°C ... +85°C
Power supply	4.8 ... 26 V DC (RS422) 4.8 ... 30 V DC (push-pull)	5 V DC (RS422) 5... 30 V DC (push-pull) (or customer-specific)

External encoders for asynchronous motors

Asynchronous motors are the all-rounders amongst electrical drives.

For every requirement there is a drive and for every drive there is a suitable Kübler encoder for mounting outside the motor. Whether as a fan motor in a small 63 size, or as a geared motor in a 225 size, asynchronous motors place special demands on encoders, above all when it comes to mechanical and electrical ruggedness. Because of their robust technology Sendix encoders prove themselves, especially in harsh environmental conditions.

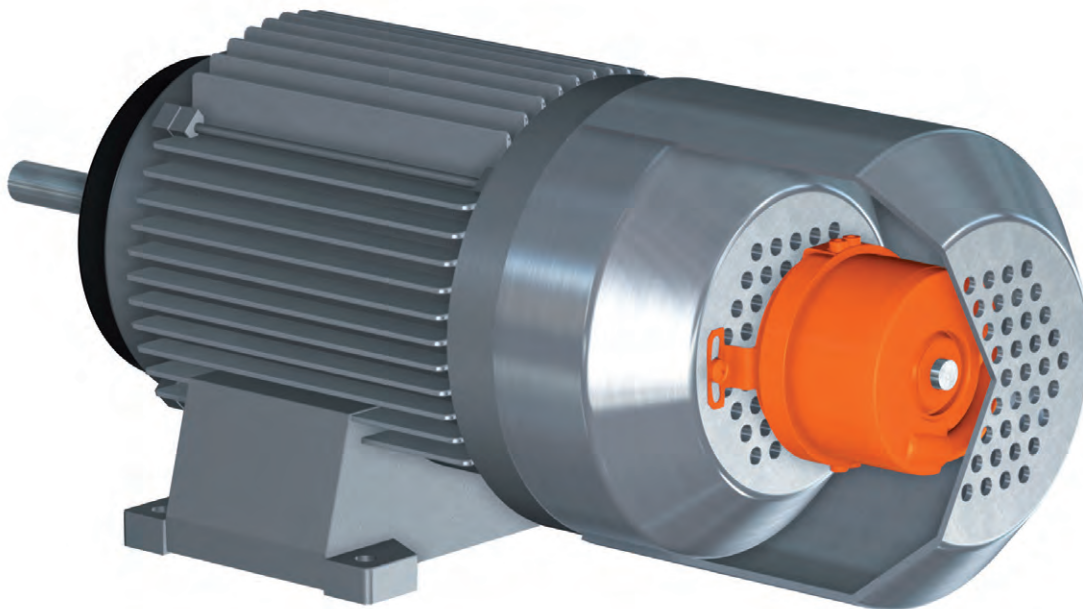

Application specific requirements

Mounting	Especially during the mounting of encoders the mechanics can be overloaded. This can lead to the encoder being prematurely damaged, so that the average service life is not reached.
Motor options	If a motor next to the encoder is to be equipped with further sensors, then the motor shaft must be fed through the encoder.
Temperature range	When using asynchronous motors extremely high temperature ranges can occur, which place increased demands on the sensors and on the way they are mounted.
Magnetic fields	Both the motor and the electromagnetic brakes create stray magnetic fields, which can affect the sensors.

Incremental encoders for mounting on asynchronous motors

The incremental Sendix encoders are available in many versions, with the suitable connection variant for almost every field of application, or as economically optimized versions. Both approaches have one in common – their compact construction.



	Sendix Base KIS40 / KIH40	Sendix 5000 / 5020	Sendix 5814 / 5834
Mechanical interface	Shaft max. 6 mm Blind hollow shaft max. 8 mm	Shaft max. 12 mm Blind hollow shaft max. 15 mm	Shaft 10 mm Blind hollow shaft max. 15 mm
Electrical interface	Push-pull, open collector, RS422	Push-pull, open collector, RS422	SinCos
Size	ø 40 mm	ø 58 mm	ø 58 mm
Resolution max.	2500 ppr	5000 ppr	2048 ppr
Speed max.	4500 min ⁻¹	12000 min ⁻¹	12000 min ⁻¹
Temperature range	-20°C ... +70°C	-40°C ... +85°C	-40°C ... +90°C
Power supply	5 V DC 10 ... 30 V DC	5 V DC 5 ... 30 V DC 10 ... 30 V DC	5 V DC 10 ... 30 V DC

Absolute encoders for mounting on asynchronous motors



The absolute Sendix encoders – available both as singleturn and multiturn versions - are first of all robust and highly accurate. The multiturn gear uses a purely optical sampling technology and is totally insensitive to magnetic fields. Moreover, the first stage is mounted on two ball bearings and underlines the robust construction of these encoders.



	Sendix 5853 / 5873	Sendix 5863 / 5883	Sendix 5863FS2/5883FS2	Sendix 5863FS3/5883FS3
Mechanical interface	Shaft max. 10 mm Hollow shaft max. 15 mm	Shaft max. 10 mm Blind hollow shaft max. 15 mm Hollow shaft max. 14 mm	Shaft 10 mm Hollow shaft max. 14 mm	Shaft 10 mm Hollow shaft max. 14 mm
Electrical interface	SSI or BiSS	SSI or BiSS	SSI or BiSS	SSI or BiSS
Size	ø 58 mm	ø 58 mm	ø 58 mm	ø 58 mm
Resolution max.	21 bit	17 bit singleturn + 12 bit multiturn	17 bit singleturn + 12 bit multiturn	17 bit singleturn + 12 bit multiturn
Speed max.	12000 min ⁻¹	12000 min ⁻¹	9000 / 12000 min ⁻¹	9000 / 12000 min ⁻¹
Temperature range	-40°C ... +90°C	-40°C ... +90°C	-40°C ... +90°C	-40°C ... +90°C
Power supply	5 V DC 10 ... 30 V DC	5 V DC 10 ... 30 V DC	5 V DC 10 ... 30 V DC	5 V DC 10 ... 30 V DC

Absolute encoders for mounting on asynchronous motors without mechanical gear



The patented Intelligent Scan Technology™, which won several awards, is the core of these absolute Sendix encoders.

These optical encoders include all singleturn and multiturn functions on an OptoASIC, therefore ensuring in the same time a very high reliability and a high resolution.

The multiturn version reaches a 24 bit resolution. Its outstanding feature is its wear-free functionality thanks to the optical sensor without mechanical gear.

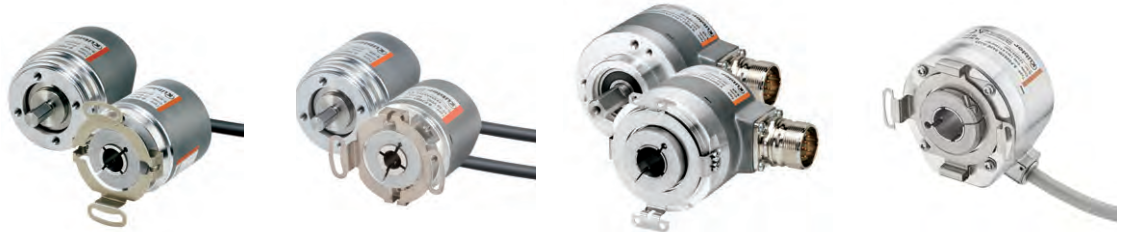

	Sendix F3653 / F3673	Sendix F3663 / F3683	Sendix F5863 / F5883	Sendix F5883M / F5888M
Mechanical interface	Shaft max. 10 mm Blind hollow shaft max. 10 mm Hollow shaft max. 8 mm	Shaft max. 10 mm Blind hollow shaft max. 10 mm Hollow shaft max. 8 mm	Shaft max. 10 mm Hollow shaft max. 15 mm	Hollow shaft max. 15 mm
Electrical interface	SSI or BiSS	SSI or BiSS	SSI or BiSS	SSI or BiSS incremental outputs SinCos and RS422, CANopen
Size	ø 36 mm	ø 36 mm	ø 58 mm	ø 58 mm
Resolution max.	17 bit singleturn	17 bit singleturn + 24 bit multiturn	17 bit singleturn + 24 bit multiturn	17 bit singleturn + 24 bit multiturn
Speed max.	12000 min ⁻¹	12000 min ⁻¹	12000 min ⁻¹	9000 min ⁻¹
Temperature range	-40°C ... +90°C	-40°C ... +90°C	-40°C ... +85°C	-40°C ... +85°C
Power supply	5 V DC 10 ... 30 V DC	5 V DC 10 ... 30 V DC	5 V DC 10 ... 30 V DC	5 V DC 10 ... 30 V DC

External encoders for large motors / generators

A tough nut. Accurate speed information is an important measurement for the control loop of a plant. Measuring systems that supply this information are often subjected to harsh environmental conditions but must not suffer any loss of reliability.

Kübler incremental encoders can handle strong vibration or extreme variations in temperature without any problem. Here, their wide-ranging mounting options guarantee easy, safe installation.

Kübler offers the complete range of solutions, from the extremely rugged Sendix Heavy Duty encoders through to the compact, bearingless encoders.

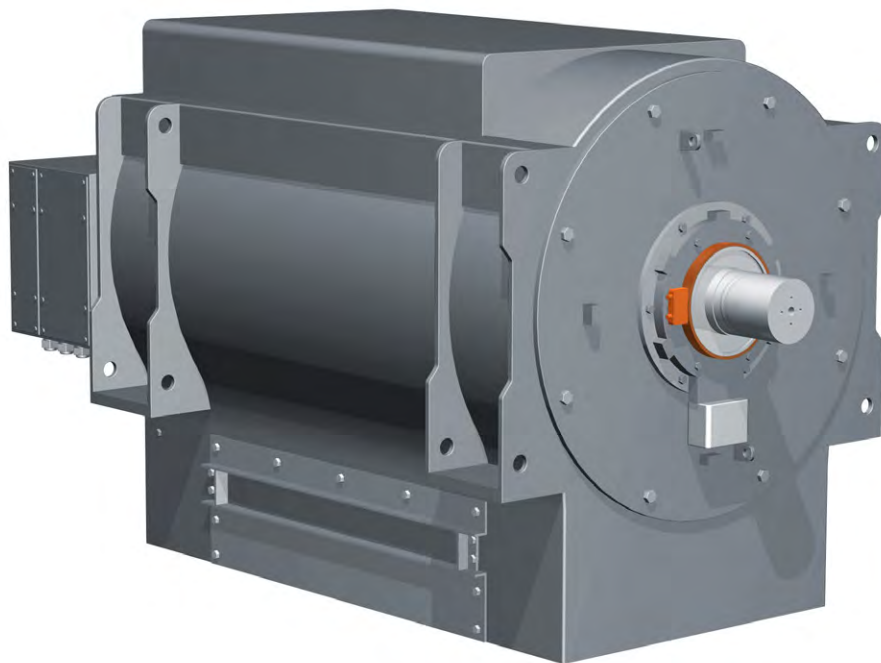

Application specific requirements

Ruggedness	The ruggedness of the sensor technology plays a crucial role with large motors and generators. Shocks and vibrations encountered in this class of drives are higher than elsewhere.
Service life / Maintenance	In applications where large motors or generators are used, downtimes are very expensive. For this reason maintenance and any replacement of a component must be very simple.
Weather / environmental conditions	Large motors are employed primarily in harsh environments. The protection class of the sensors is thus correspondingly important, so that breakdowns can be avoided.
High currents	Despite well-earthed machine housings, large motors and generators carry a certain shaft current on the rotor. The equipotential bonding from the rotor to the stator via the encoder bearings can damage the encoder.

Incremental encoders for large motors / generators

Many different Kübler encoders have been designed for use in large motors and generators.

Compact versions, Sendix Heavy Duty encoders for extreme bearing loads or bearingless versions for long service life – Kübler encoders are exactly adapted to the application-specific requirements.

In the end, it is the application that will decide which encoder will be used.



	HDRI500, HDRI5000	A020, A02H	Sendix Heavy Duty H120
General information	For mounting on large shaft diameters	Tight mounting conditions and applications with high bearing forces	Applications with high bearing loads and very high shaft currents
Mechanical interface	Mounting on shafts up to \varnothing 740 mm	Hollow shaft max. 42 mm	Hollow shaft max. 28 mm
Electrical interface	Push-pull, RS422, SinCos (opt. SSI, BiSS, analog)	Push-pull, RS422, SinCos	Push-pull, RS422
Size	100 x 60 x 25 mm	\varnothing 100 mm	\varnothing 100 mm
Resolution max.	On request (resolution depends on magnetic ring diameter)	5000 ppr	5000 ppr
Speed max.	max. 12000 min ⁻¹ (depends on magnetic ring diameter)	6000 min ⁻¹	6000 min ⁻¹
Temperature range	-20°C ... +80°C	-40°C ... +80°C	-40°C ... +100°C
Power supply	5 V DC 5 ... 30 V DC 10 ... 30 V DC	5 V DC 5 ... 30 V DC 10 ... 30 V DC	5 V DC 10 ... 30 V DC

External encoders for stepper motors

Every millimeter counts with stepper motors. Usually only limited installation space is provided for the sensors. We offer you the right solutions for speed measuring. High resolution with simultaneously compact design – these are the miniature and compact encoders from Kübler. The robustness, quality and reliability speak for themselves.

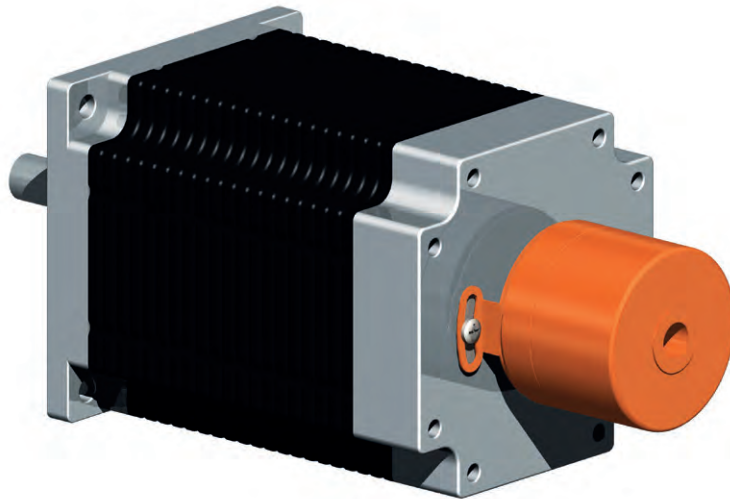

Application specific requirements

Mounting	The small dimensions make these motors an ideal solution when space is limited. That means compact sensors are essential.
Resolution	Stepper motors provide high torque at low speeds. This calls for high resolution sensors.
Accuracy	Stepper motors equipped with highly accurate optical sensors are used for precision in positioning tasks.

External encoders for stepper motors

The incremental miniature and compact encoders from Kübler are ideal for speed measuring in tight installation spaces or spatial conditions. Numerous ordering options are available to you. We are also happy to implement modifications and special solutions.



	2400 / 2420	2430 / 2440	3610 / 3620	3700 / 3720
General information	Incremental miniature encoder with optical sensor	Incremental miniature encoder with magnetic sensor	Incremental compact encoder with optical sensor	Incremental economy encoder with optical sensor
Mechanical interface	Shaft max. 6 mm Blind hollow shaft max. 6 mm	Shaft max. 6 mm Blind hollow shaft max. 6 mm	Shaft max. 6 mm Hollow shaft max. 8 mm	Shaft max. 8 mm Hollow shaft max. 8 mm
Electrical interface	Push-pull	RS422	Push-pull, RS422	Push-pull, RS422
Size	ø 24 mm	ø 24 mm	ø 36 mm	ø 37 mm
Resolution max.	1024 ppr	256 ppr	2500 ppr	1024 ppr
Speed max.	12000 min ⁻¹	12000 min ⁻¹	12000 min ⁻¹	6000 min ⁻¹
Temperature range	-20°C ... +85°C	-20°C ... +85°C	-20°C ... +85°C	-20°C ... +70°C
Power supply	5 ... 24 V DC 8 ... 30 V DC	5 V DC	5 V DC 5 ... 18 V DC 8 ... 30 V DC	5 V DC 5 ... 30 V DC 10 ... 30 V DC

Magnetic length measuring systems for linear motors

Linear motors are versatile to use. They are often used in wood processing machines, solar energy systems, glass processing or even in medical technology. Each application thus places different requirements on the entire system. Kübler offers you the right measuring system. This is characterized by robustness, quality and reliability.

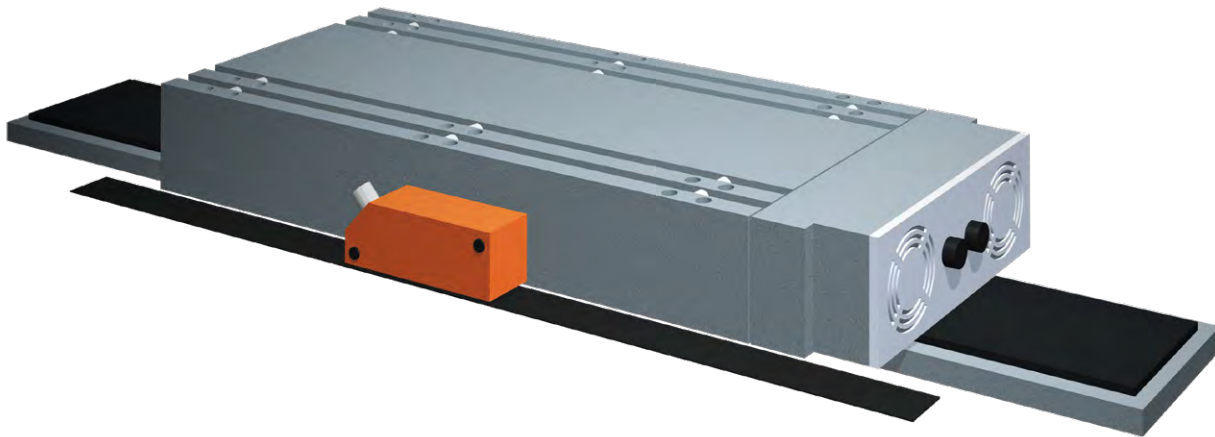

Application specific requirements

Robust	Highly robust sensors are required when using linear motors in rough environments.
Installation	A corresponding measuring system is used for direct, translational motion (linear motion).
Speed	Linear motors are characterized by high travel speeds. A fast measuring system is therefore relevant.

Magnetic length measuring systems for linear motors

The Limes product family is a very compact solution for non-contact magnetic scanning and represents a cost-effective alternative in applications that do not require the high accuracy of glass scales. This magnetic measuring system shows its strong points especially in the presence of dirt, oils and humidity. Therefore, this measuring system is optimally suited for use in the linear drive technology.



	Limes LI20 / B1	Limes LI50 / B2	Limes LA10 / BA1	Limes LA50 / BA5
General information	Linear measuring technology for linear motors	Linear measuring technology for linear motors	Linear measuring technology for linear motors	Linear measuring technology for linear motors
Electrical interface	RS422 / push-pull	RS422 / push-pull	Absolute SSI / BiSS incremental SinCos absolute fieldbus	Absolute SSI / BiSS absolute fieldbus
Size	10.2 x 25 x 40 mm	10.2 x 25 x 40 mm	16 x 30 x 70 mm	24 x 26 x 75 mm
Resolution max.	10 µm	5 µm	1 µm	10 µm
Measuring length	max. 70 m	max. 70 m	max. 8 m	max. 20 m
Accuracy	Depends on measuring length 0.06 mm at 1 m	Depends on measuring length 0.08 mm at 1 m	Depends on measuring length 0.03 mm at 1 m	Depends on measuring length 0.17 mm at 1 m
Temperature range	-20°C ... +80°C	-20°C ... +80°C	-10°C ... +70°C	-10°C ... +70°C
Type of connection	Cable	Cable	M12 connector	Cable

Encoders for elevator technology

Encoders for elevator motors are available in various versions. In order to provide the suitable solution for every motor, Kübler offers a wide encoder portfolio for the manufacturers of geared motors, gearless drives up to external rotor motors.





Encoders for gearless motors

The advantages of the gearless motors are first of all a high torque at small rotary frequencies and smooth and silent operation. Encoders for these applications must above all be flexible in terms of electrical interfaces and mounting possibilities.

Incremental encoders Sendix 5834 Motor-Line (tapered shaft)
Absolute encoders singleturn Sendix 5873 Motor-Line (tapered shaft)

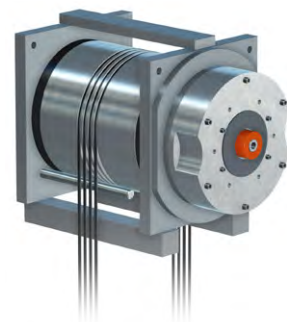

Bearingless encoders for direct drives (external rotor motors)

The bearingless encoders are made of a magnetic ring and a sensor head. They are predestined for external rotor motors, which, thanks to their compact and flat construction, can be integrated directly in the elevator shaft. Individual adaptation of the measuring system to the dimensions of the drive are here one of the most important prerequisites.

Bearingless encoders RLI500, RLI50,
 RLI200, RLI20



Encoders for geared motors

In geared motors, an incremental encoder mounted between the motor and the hand wheel measures the rotational speed for speed control and transmits it to the complete drive module (CDM). These encoders feature a large hollow shaft and compact dimensions, together with a high resolution.

Incremental encoders 5821, A020, A02H (hollow shaft)

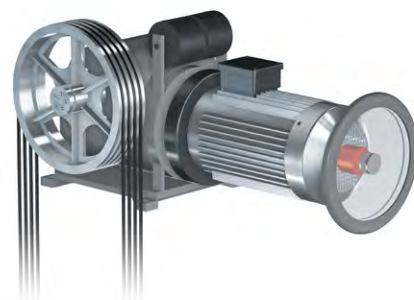

Explosion protection – ATEX / IECEx

In hazardous areas encoders must comply with special protective regulations, as even the smallest spark can have very serious consequences.

Positioning tasks occur in many hazardous environments – whether in mining, in the chemical industry or also in oil production.

Especially for those applications that require absolute position values, Kübler offers the Sendix absolute encoders with ATEX / IECEx approval. The singleturn and multiturn ATEX encoders with “flameproof-enclosure” housings are approved for zones 1, 2, 21 and 22 and certified according to the ATEX guidelines and IECEx standards.





Sendix ATEX / IECEx encoders

The shock and vibration resistant ATEX / IECEx encoders operate flexibly with a resolution of up to 17 bits (singleturn) and 29 bits (multiturn).

In addition the incremental version supplies a push-pull, RS422 or SinCos signal. With their IP67 protection level and wide temperature range of -40°C up to +60°C, the ATEX / IECEx encoders remain sealed even under the rigours of tough everyday use and offer good security against failures in the field. Thanks to the housing and flange made of seawater durable aluminum they are ideal for use in offshore and coastal applications. The compact design with an installation depth of only 145 mm, a diameter of 70 mm and a space saving cable outlet round off the diverse, flexible options for use in hazardous EX areas.

Standard ATEX encoders

Incremental:	Sendix 7000 / Sendix 7020 (shaft / hollow shaft)
Singleturn:	Sendix 7053 / Sendix 7073 (shaft / hollow shaft) Sendix 7058 / Sendix 7078 (shaft / hollow shaft)
Multiturn:	Sendix 7063 / Sendix 7083 (shaft / hollow shaft) Sendix 7068 / Sendix 7088 (shaft / hollow shaft)

ATEX encoders certified up to SIL3

Incremental:	Sendix 7014FSx / Sendix 7034FSx (shaft / hollow shaft)
Singleturn:	Sendix 7053FSx / Sendix 7073FSx (shaft / hollow shaft)
Multiturn:	Sendix 7063FSx / Sendix 7083FSx (shaft / hollow shaft)

Functional Safety

Safety is – not least since the EU Machinery Directive 2006/42/EC – an “integral part of the construction of drives”.

When choosing the right encoder for functional safety the principle applies that safety is achieved through the intelligent combination of encoder, controller and actuator.

But safety goes further than this: safe components are characterized by a robust reliable interface and by the ability to cope with high mechanical and electronic loads. Both Sendix encoders with SSI absolute and additional SinCos interface and also the SinCos version of the incremental encoders have been certified up to SIL3 by TÜV Rheinland.





Encoders for Functional Safety

In order to achieve safe incremental information with the encoder, the controller must monitor the validity of the analog, 90° phase-shifted sine/cosine signals with the help of the function:
 $\sin^2 + \cos^2 = 1$.

In order to obtain safe information with the encoder regarding the absolute position, the controller counts the incremental pulses and compares the result with the absolute position also provided by the encoder. A 100 % reliable mechanical connection is required for a safe function in the applications. Suitably sturdy fixing elements can help eliminate the risk of faults.

Incremental SinCos encoders

Sendix 5814FS2 / FS3 (shaft)
Sendix 5834FS2 / FS3 (hollow shaft)

Absolute singleturn SSI / SinCos encoders

Sendix 5853FS2 / FS3 (shaft)
Sendix 5873FS2 / FS3 (hollow shaft)

Absolute multiturn SSI / SinCos encoders

Sendix 5863FS2 / FS3 (shaft)
Sendix 5883FS2 / FS3 (hollow shaft)

Overview electrical interfaces

Encoders have various tasks to fulfil in elevator engineering.

One of the most frequent tasks is to supply information concerning speed, for better control of the motor using a CDM – Complete Drive Module. For this type of speed control motor feedback is necessary, which is suitable for improving the speed quality and the control response. As a rule a SinCos or TTL / HTL signal is used for this purpose.

A further task is the positioning of the drive. This can occur both incrementally and absolutely. The dynamic control of synchronous servo motors requires the feedback of the rotor position within a revolution.

This is achieved using singleturn absolute encoders with a BiSS or SSI interface.

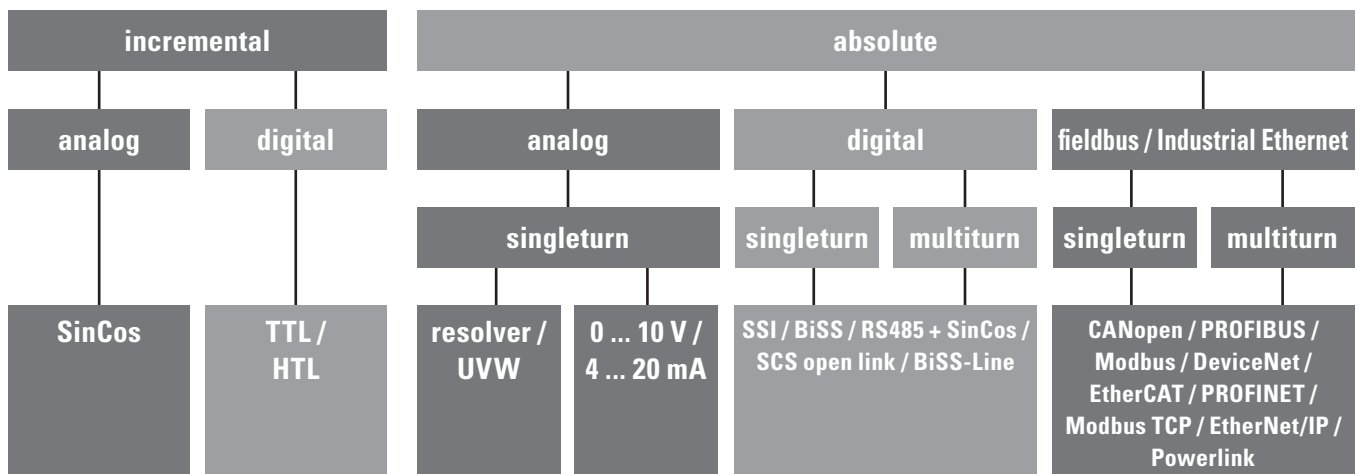

Single Cable Solutions

The Single Cable Solutions combines the motor power supply line and the data communication in one single cable. Requiring less cables and connectors, this technology simplifies installation and thus reduces in the same time the error sources.

Not all protocols are suitable. They must be specially tailored to this application, such as for example SCS open link or BiSS Line.

Safety is not simply a trend, but it is establishing itself as a standard in the drive technology. It is therefore important to pay attention to safety-relevant characteristics when choosing the interface.

Field buses or industrial Ethernet interfaces are principally used in the application and are not directly involved in speed regulation. The position control can operate with these encoders.



Incremental interface (SinCos, TTL / HTL)

The SinCos interface provides a sine wave-shaped voltage signal. High-quality encoders allow very high interpolation of this signal, which benefits the speed control. This means that the SinCos signals can be processed in many various ways in the subsequent electronics. The steady signal evolution makes sure that signal information is available at any time. This is an advantage in drives for speed control, even for very slow motions.

The cosine precedes the sine by 90° so that one of the signals emits a valid value also when passing the zero point. This is also the great difference with digital incremental signals such as HTL or TTL. These have signal states in which both channels A and B can have simultaneously the value zero or one, which does not allow detecting errors.

By contrast, even though the encoders with incremental interface (TTL / HTL) also generate a sine wave shaped scanning signal, this signal is then digitized in the encoder and provided to the subsequent electronics as a rectangular pulse. Various output types are available for transmission.

SSI interface

The synchronous serial interface (SSI) is a digital interface for absolute encoders. This means that the SSI interface allows digital and absolute transmission of motion or angular information. It is therefore particularly well suited for applications requiring reliability and signal robustness in industrial environments. Another advantage is the fact that transmission requires significantly less lines than parallel interfaces. It also allows much longer cable lengths.

At rest, the clock and data lines are at a high level. With the first falling clock-pulse edge, the current encoder data are stored in the buffer ready to be sent. With the next rising clock-pulse edge, the data are transmitted bit by bit, starting with the MSB.

The transfer of a complete data word requires $n+1$ rising clockpulse edges (n =resolution in bit), e.g. 14 clock signals for a complete readout of a 13 bit encoder.

After the last positive going clock-pulse edge the data line will remain for the duration of the monoflop time t_3 at a low level, until the encoder is ready for a new data word. The clock line must stay high for at least as long, and then can begin a new readout sequence again with the next falling edge.

BiSS interface

The BiSS interface is a fully-digital bidirectional connection for absolute measuring systems. Therefore, BiSS is perfectly suited for dynamic axes with very high accelerations, constant speed control and best positioning accuracy possible.



Advantages of the BiSS interface

The great advantage of the BiSS interface is its open source protocol for sensors, inverters and drives, offering e.g. high speeds (data rate up to 10 MHz) and a delay compensation for the optimal operation of the drive system. The selection of the components is not imposed by a licensed interface, but only by the requirements of the application, which results in more flexibility and higher cost-efficiency.

- BiSS is fully-digital and bidirectional and is perfectly suited as a motor feedback system for both linear and rotary axes.
- BiSS is not proprietary and therefore cost-efficient and flexible. This ensures a much wider choice of available products.
- The inverters equipped with an RS422 and RS485 interface can mostly be used for BiSS thanks to an extension with a firmware update for BiSS, thus opening the possibility of using an open source interface.
- There is nevertheless also the possibility of a quick and simple BiSS Master implementation with free BiSS IPs on processors and FPGAs.
- Advantages for the commissioning of motor and inverter thanks to plug-and-play using the motor data and maintenance information that can be stored in and retrieved from the encoder and to the possibility to set the absolute measuring system to a predefined position value.
- Information and evaluation of the complete system during operation thanks to Condition Monitoring and to the delay compensation for accelerated communication, e.g. to minimize drift effects due to temperature.



kuebler.com/biss

BiSS SAFETY

BiSS Safety is entirely based on BiSS C and uses all of its protocol options. All identification features, electronic data sheets and diagnosis possibilities are entirely preserved.

The further development of BiSS for safety-relevant applications (BiSS Safety) presupposed the following functionalities:

- Achieving SIL2 and SIL3 with the existing BiSS protocol
- Keeping all physical interfaces for the use of existing and new sensors

The external structure remains a point-to-point wiring such as for a standard BiSS protocol. But, inside the device, two independent sensors are used for generating the position data and securing the transmission. BiSS Safety uses here the 'Black Channel' approach for safe data communication.

BiSS LINE

BiSS Line uses standard components available on the market for the cables and connectors and transmits the 8B10B-encoded BiSS data via RS485 PHYs using the known 2 or 4-wire technology.

The transmission speed of 12.5 MBaud is comparatively high. The unique features of BiSS Line are: open-source interface for Single Cable Solutions and bus structure for multiple slaves. An essential point is the implementation of a forward error correction (FEC), which is a prerequisite for high availability of the data communication even with disturbed and poor-quality cables and connectors.

Fixing and connection solutions

Perfect integration into the drive can only be successful if an optimal connection of the encoder to the motor is made.

For the rotating motor shaft and motor housing Kübler offers a wide choice of standard fixing and connection options, with which the desired encoder variants can be combined in a modular design principle. In addition to this individual, customized solutions can be worked out.

Fixing on the motor housing

Torque stop

For applications with axial and radial play with constant rotary movements.



Stator coupling

For applications with axial and radial play with high dynamics.



Tether arm

For applications with low axial and radial play, flexible in use.



Individual fixing solutions

E.g. ez Fan-clip – mounting solution on fan grill.
For instant easy fixing of the encoder directly onto the fan grill of the gear housing.



Fixing to the motor shaft

Shaft

Simple mounting on various shaft diameters via suitable couplings.

- Easy to centre
- Long service life
- Max. tolerance
- High speed



Hollow shaft

Accurate centring and reduced vibration.

- Long service life
- Max. tolerance
- High accuracy

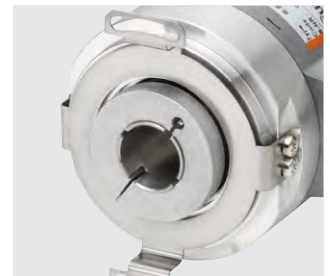

Safety-oriented coupling

For applications requiring safe transmission of the rotary movement.





Additional accessories at: kuebler.com/accessories
 Additional connection technology at: kuebler.com/connection_technology

Connection solutions

Standard connection solutions

- PCB plug-in connectors: M12, M23, MIL
- Cable connection
- Terminal box
- Optical fiber signal transmission technology
- PCB connectors



Individual connection solutions

Kübler offers space-saving installation options for M12 and M23 connectors under the fan cowl.

- Lead-through M12 straight, IP67
- Male connector with external thread, IP67, central fastening



Accessories connection technology

Cables

All cables – for incremental, absolute and fieldbus encoders – can also be ordered by the metre as open-ended cable:

- PVC and PUR cables
- Halogen-free cables
- Bus cables



Connectors

Kübler offers a range of connectors for self-assembly with a protection level of up to IP67, for example as male connector M23 with external thread or as socket with metal union nut.



Cordsets, pre-assembled

Kübler offers pre-assembled cordsets in a variety of connector versions as well as with a different number of cores (5, 8, 10, 12, 18).



Optimal solutions thanks to customer-specific development

The ideal sensor for your drive – that is our goal: for simple, fast and error-free mounting – highest reliability of the signals – long service life and minimum costs.

During development of customer-specific solutions Kübler focuses on 3 principles:

- Lean Design (coordinating the materials and functionality to the application)
- Design to Cost (aligning development to target costs)
- Cost of Ownership (fast installation, simple maintenance, long service life)

Fixing solutions

The correct mounting and fixing solution of an encoder in a drive is crucial for reliable operation and peace of mind. The wide variety of drives and the increasing demands placed on drives (especially in respect of installation space) pose new challenges every day.

By the use of intelligent solutions, closely matched to the drive, great savings can be made when it comes to space, time and costs. Furthermore, specific fixing elements can be developed, which are tailored to the installation space of the housing or the geometry of the flange and shaft; this ensures an optimal connection and the highest degree of accuracy.

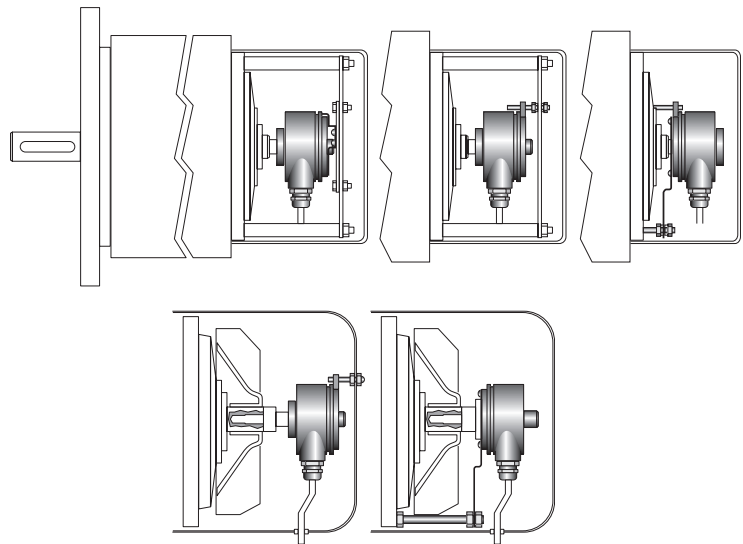

Connection solutions

The cable and connectors used to connect an encoder with the PLC must be matched to the installation space available as well as being capable of withstanding the prevailing environmental conditions such as humidity, cold or heat.

Here too, the setting-up of special cables or the development of specific connectors can lead to the right solution.

In particular, the cable or connector transition from the motor housing to the outside world requires innovative constructions, in order to guarantee reliability and freedom from errors.

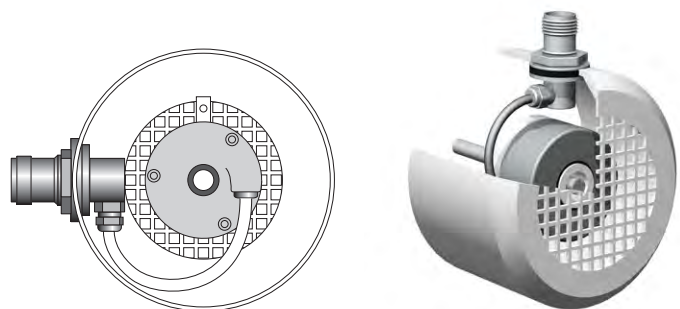

Protection concepts

Kübler does not leave protection of its sensors to chance. The application areas for drives are very diverse. Kübler has designed appropriate specific protective covers, which take into consideration the design of the encoder, as well as the IP protection level, temperature and operating conditions. With its extensive experience in difficult application areas, such as steel production, wind turbines or in mobile applications, Kübler has developed special housing and seal designs, as well as coating solutions, which also withstand the high demands of outdoor applications in respect of condensation or extreme fluctuations in temperature.

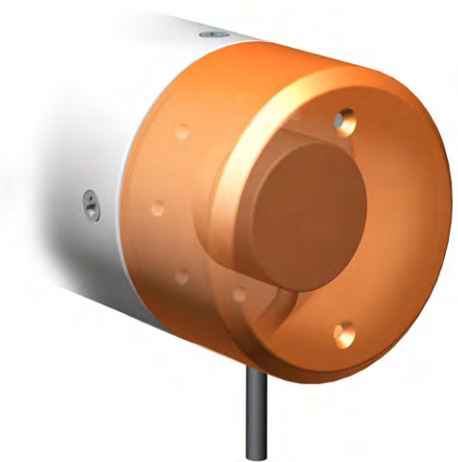

Advantages of customized integrated drive solutions

- High reliability, as all component parts have been specifically designed for your drive.
- Particular focus on a longer service life when selecting the product.
- Simple, fast mounting thanks to a high degree of integration.
- Development of solutions for simple maintenance.
- Warranty and support from a single source.
- Reduced costs, as the solution is directly tailored to the drive. No "over-engineering".

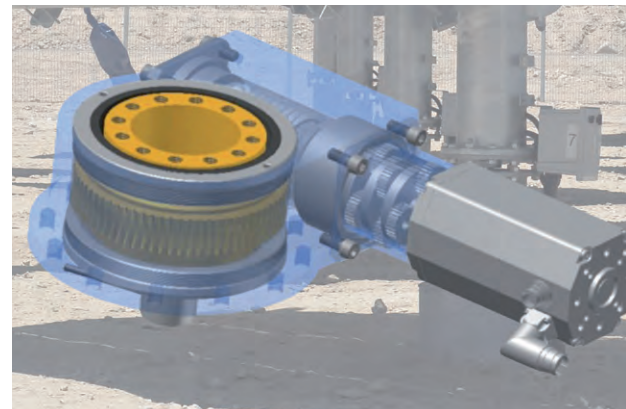

Product portfolio – Made in Germany

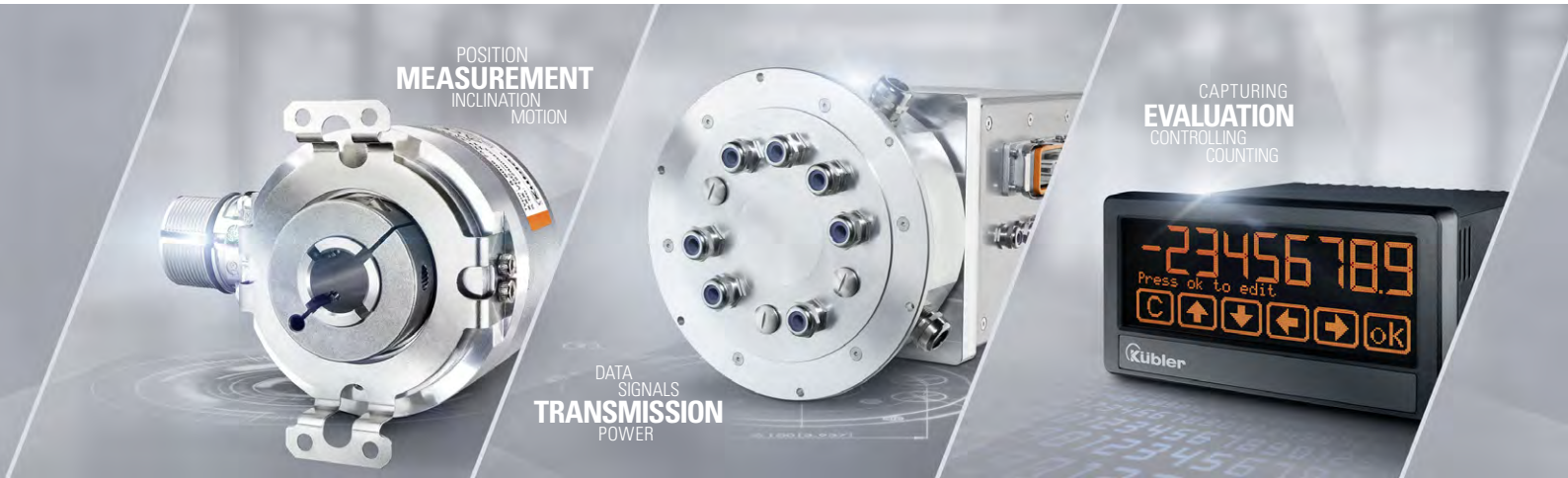

MEASUREMENT

Rotary speed and position detection, linear position, and speed measurement as well as inclination angle detection.

- Encoders
- Bearingless encoders
- Motor Feedback Systems
- Linear measuring technology
- Shaft copying systems
- Inclinometers

TRANSMISSION

Reliable and interference-free transmission of electrical currents, signals, and data. Communication between control system and sensors.

- Slip rings, standard
- Slip rings, customized solutions
- Signal converters
- Cables and connectors

EVALUATION

Recording of quantities, counting of units of any kind, and reliable speed and position recording for functional safety.

- Displays and counters
- Process equipment
- Safe speed monitors up to SIL3/PLE

We offer solutions for the following industries:



The high performance level and reliability of the Kübler products are based on our long experience in these demanding application sectors. Learn more about our application-specific solutions under:

kuebler.com/industries

Kübler Service for worldwide planning reliability



24one

24one delivery promise

Manufacturing in 24 hours. For orders placed on working days before 9 AM, the product will be ready for dispatch on that same day. 24one is limited to 20 pieces per delivery.

10 by 10

10 by 10

We will manufacture and deliver 10 encoders within 10 working days (365 days a year - with the exception of 24th Dec. until 2nd Jan.)

48 h

48 h Express-Service

We can process your order within 48 hours; we can ship stock items the same day.

Phone icon

Technical Support

Kübler' applications team is present on site all over the world for advice, analysis and support.

Kübler Germany / Austria +49 7720 3903 952
 Kübler France +33 3 89 53 45 45
 Kübler Italy +39 026 423 345
 Kübler Poland +48 61 84 99 902

Wrench icon

Sample Service

We manufacture samples of special designs or according to customer specification within shortest time.

FS icon

Safety Services

- Adapted service packages
- Individual customer solutions

Key icon

Tailor-made Solutions – Kübler Design System (KDS) OEM Products and Systems (OPS)

We develop jointly with our customers product and engineering solutions for customer-specific products, integrated drive solutions, up to complete systems.

Kübler Turkey +90 216 999 9791
 Kübler China +86 10 8471 0818
 Kübler India +91 2135 618200
 Kübler USA +1 855 583 2537

Kübler worldwide

490 employees worldwide · 4 production sites · presence in over 50 countries

Europe

Austria
Belarus
Belgium
Bulgaria
Croatia
Czech Republic
Denmark
Estonia
Finland
France
Germany
Great Britain
Greece
Hungary
Iceland
Ireland

Lithuania
Italy
Netherlands
Norway
Poland
Portugal
Russia
Slovakia
Slovenia
Spain
Sweden
Switzerland
Turkey
Ukraine

Africa

Egypt
Morocco
South Africa
Tunisia

North and South America

Argentina
Brazil
Canada
Mexico
Peru
U.S.A.

Oceania

Australia
New Zealand

Asia

China
Hong Kong, China
India
Indonesia
Israel
Lebanon
Malaysia
Philippines
Singapore
South Korea
Taiwan, China
Thailand
United Arab Emirates
Vietnam

Kübler Group

 Fritz Kübler GmbH
Germany

 Kubler SP. Z O.O.
Poland

 Kuebler (Beijing) Automation Trading Co. Ltd.
China

 Fritz Kübler SARL
France

 Kübler Turkey Otomasyon Ticaret Ltd. Sti.
Turkey

 Kuebler Korea (by F&B)
South Korea

 Kübler Italia S.r.l.
Italy

 Kuebler Inc.
USA

 Kübler Österreich
Austria

 Kuebler Automation India Pvt. Ltd.
India

Kübler Group

Fritz Kübler GmbH

Schubertstrasse 47
78054 Villingen-Schwenningen
Germany
Phone +49 7720 3903-0
Fax +49 7720 21564
info@kuebler.com
www.kuebler.com

kuebler.com/drives