

Temperature controllers

LED temperature controllers

For temperature sensors with limit value (AC+DC)

Codix 564



The temperature controller Codix 564 displays temperature values in high resolution. In addition it can monitor and control 2 limit values. All current temperature sensors, such as thermocouple types B, E, J, K, N, R, S and T, as well as mV inputs, Pt100 and resistance inputs, can be connected to the device.

These fast displays set new standards when it comes to user friendliness. Their easy-to-read 14-segment LED display, easy-to-understand running help texts and a practical quick-start guide eliminate the need to wade through time-consuming full instruction manuals.

With optional analog output.

DC 10 ... 30 V Power supply	AC 100 ... 240 V Power supply	A..Z* 6 LEDs 14-segment LED display	Prog Menu-driven programming	mV, Ω Display linearization	Temperature input Temperature input	2, 3, 4 2-, 3-, 4-wire technology	min / max Min / Max value detection	2 2 limit values	AC/DC Galvanic isolation	15 bit Resolution
-20° + 65° Temperature range	DIN 96 x 48 DIN front bezel	Installation in mosaic systems	Operation with gloves	mA, V Analog output optional						

User-friendly

- Practical quick-start guide for setting the parameters and operating the device.
- Help text as running text.
- Easy-to-read 14-segment LED, 6-digit display, 14 mm high.
- Simple programming via 4 keys on the front.
- One front key as well as 2 additional inputs can be programmed for specific applications.
- Characteristic curves for thermocouples and RTD permanently stored.
- MIN/MAX memory function, individually resettable.

Powerful

- Sampling rate of 10 readings per second.
- Customized linearization via 12 control points.
- 2 relay outputs (changeover contacts) for limit monitoring with hysteresis and ON/OFF delay function.
- Analog output for the current measured value, MIN-value, MAX-value.
- Auxiliary sensor power supply with AC version.
- Inputs and outputs galvanically isolated.
- Digital filter (first-order) for smoothing display fluctuations with unstable input signals.

Order code

6.564 . 0 1 0 . X 0 X

- a** Input type
4 = Temperature signal input ¹⁾
- b** Outputs
0 = relays ¹⁾
- c** Power supply
0 = 100 ... 240 V AC, ±10 % ¹⁾
3 = 10 ... 30 V DC ¹⁾
- d** Further outputs (optional)
0 = none ¹⁾
9 = analog output ¹⁾
(only for DC version)

Delivery specification:

- Process device
- Mounting clip
- Gasket
- Instruction manual, multilingual
- 1 sheet of self-adhesive symbols
- Quick-start guide

Practical quick-start guide for setting the parameters and operating the device.

The guide can be affixed directly to the front of the unit and can be removed and re-applied as required.



1) Stock types.

Temperature controllers

LED temperature controllers For temperature sensors with limit value (AC+DC) Codix 564

Accessories	Dimensions in mm [inch]	Order no.
Mounting frame with cut-out 92 x 45 [3.62 x 1.77]	for snap-on mounting on 35 [1.38] top-hat DIN rail, for counters 96 x 48 [3.74 x 1.89]	grey G300005

Suitable gaskets as well as further accessories can be found in the accessories section or in the accessories area of our website at: www.kuebler.com/accessories.

Technical data

General technical data	
Display	6-digit, 14 segment LED
Digit height	14 mm [0.55"]
Display range	-199999 ... 999999, with leading zero blanking
Data retention	> 10 years, EEPROM
Operation	5 keys
Operating temperature	-20°C ... +65°C [-4°F ... +149°F] (non-condensing)
Storage temperature	-25°C ... +75°C [-13°F ... +167°F]
Relative humidity (non-condensing)	R.H. 93 % at +40°C [+104°F]
Altitude	up to 2000 m [6562']

Electrical characteristics	
Power supply	AC supply 100 ... 240 V AC / max. 9 VA, 50 / 60 Hz, tolerance ±10 % ext. fuse protection: T 0.1 A DC supply 10 ... 30 V DC / max. 3.8 W with galvanic isolation and reverse polarity protection ext. fuse protection: T 0.4 A
Mains hum suppression (programmable)	50 Hz or 60 Hz
Sensor power supply	AC supply 24 V DC ±15 %, 30 mA
EMC standard	EN 55011 class B EN 61000-6-2, EN 61000-6-3 with shielded signal and control cables
Device safety	designed to EN 61010 part 1 protection class 2 (front side) application area pollution level 2 overvoltage category II
UL approval	file E128604

Measuring signal inputs	
Sampling rate	10 readings/sec
Temperature drift	< 100 ppm/K _{Ambient}
Input Thermocouple	
thermocouple:	range: accuracy at 23°C [73.4°F]:
type B	+250°C ... 1820°C [+482°F ... 3308°F] typ. 1.0°C, max. 2.0°C
E	-200°C ... +1000°C [-328°F ... +1832°F] typ. 0.2°C, max. 0.5°C
J	-210°C ... +1200°C [-346°F ... +2192°F] typ. 0.2°C, max. 0.5°C
K	-200°C ... 499.9°C [-328°F ... +931.82°F] -500°C ... +1372°C [-868°F ... 2502°F] typ. 0.6°C, max. 1.0°C typ. 0.3°C, max. 0.5°C
N	-200°C ... +1300°C [-328°F ... 2372°F] typ. 0.3°C, max. 0.7°C
R	-50°C ... +1768°C [-58°F ... +3214°F] typ. 1.0°C, max. 2.0°C
S	-50°C ... +1768°C [-58°F ... +3214°F] typ. 1.0°C, max. 2.0°C
T	-200°C ... +400°C [-328°F ... +752°F] typ. 0.2°C, max. 0.5°C
Resolution J, K, T, E, N	1 or 0.1°C/°F
Resolution S, R, B	1°C/°F
Reference point	internal or external constant
Reference point accuracy	≤ ±1°C
Input mV	
Measuring range	±105 mV (resolution ±15 bit)
Measuring accuracy at 23°C [73.4°F]	typ. 0.02 / max. ≤ 0.05 (% of range)
Input resistance	> 2 MΩ
Input Pt100	
Measuring range	-200°C ... +850°C [-328°F ... +1562°F]
Resolution	1 or 0.1°C / °F
Measuring accuracy at 23°C [73.4°F]	typ. 0.3°C, max. ≤ 0.6°C
Measuring current	200 µA
Connection	2-, 3-, 4-wire
Lead wire resistance	max. 25 Ω per wire
Input 500 Ω	
Measuring range	0 ... 525 Ω (resolution ±15 bit)
Measuring accuracy at 23°C [73.4°F]	typ. 0.1 Ω, max. ≤ 0.2 Ω
Measuring current	200 µA
Connection	2-, 3-, 4-wire
Lead wire resistance	max. 25 Ω per wire

Temperature controllers

LED temperature controllers For temperature sensors with limit value (AC+DC) Codix 564

Mechanical characteristics	
Housing	Panel mount housing to DIN 43700 RAL 7021
Dimensions	96 x 48 x 102 mm [3.78 x 1.89 x 4.02"]
Panel cut-out	92 +0.8 x 45 +0.6 mm [3.62 +0.032 x 1.77 +0.024"]
Installation depth	approx. 92 mm [3.62"] incl. terminals
Weight	approx. 180 g [6.34 oz] with analog output 200 g [7.06 oz]
Protection	IP65 (front side)
Housing material	Polycarbonate UL94 V-2
Vibration resistance acc. to EN 60068-2-6	10 - 55 Hz / 1 mm / XYZ 30 min in each direction
Shock resistance acc. to EN 60068-2-27	100 G / 2 ms / XYZ 3 times in each direction
acc. to EN 60068-2-29	10 G / 6 ms / XYZ 2000 times in each direction
Connections	
Power supply and outputs	Plug-in screw terminal, 8-pin, RM 5.00, core \varnothing max. 2.5 mm ² [AWG 13]
Signal and control inputs	Plug-in screw terminal, 9-pin, RM 3.50, core \varnothing max. 1.5 mm ² [AWG 15]

Alarm outputs	
Relays	changeover contacts
Switching voltage	max. 250 V AC / 125 V DC min. 5 V AC / 5 V DC
Switching current	max. 5 A AC / 5 A DC min. 10 mA DC
Switching capacity	max. 1250 VA / 150 W
Pull-in time	approx. 10 ms

Analog output (optional - only for DC version)	
Output ranges	0 (4) ... 20 mA / 0 (2) ... 10 V
Load	current output $\leq 500 \Omega$ voltage output $\geq 2000 \Omega$
Resolution	15 bit
Update time (basic device measuring rate)	100 ms
Temperature drift	$\leq 100 \text{ ppm/K}_{\text{Ambient}}$
Accuracy	$\pm 0.1 \%$ of the output range high value
Output ripple	$\leq 10 \text{ mV}$
Isolation voltage	500 V AC for 1 minute or 1 kV DC for 1 second

Control inputs MPI 1 / MPI 2	
Quantity	2 optocouplers
Function	programmable
Switching levels	LOW $< 2 \text{ V}$ HIGH $> 4 \text{ V}$ (max. 30 V)
Pulse length	$> 100 \text{ ms}$

Terminal assignment

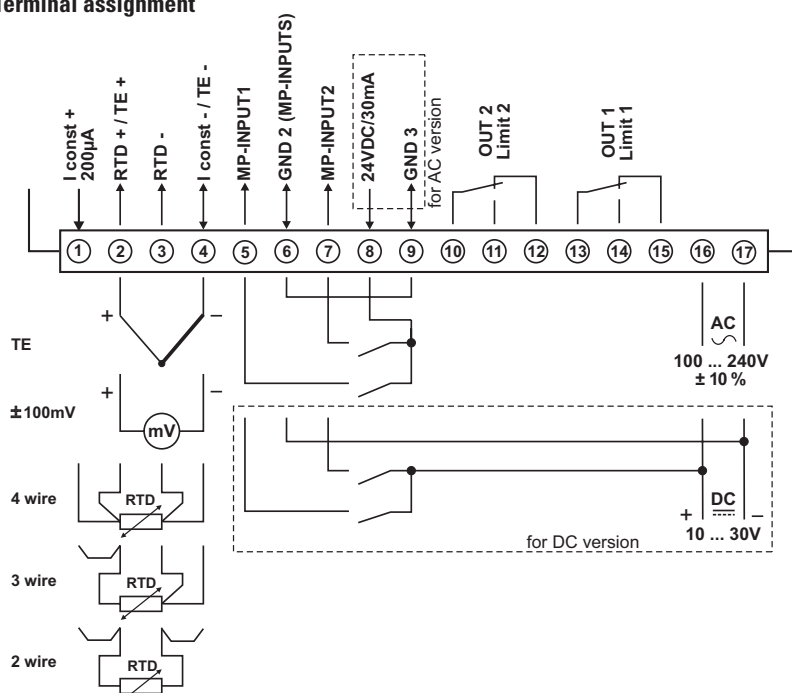

Rear side view

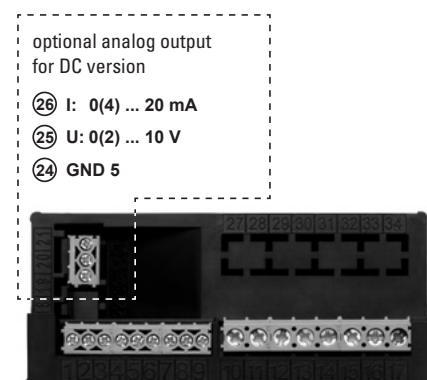

Temperature controllers

LED temperature controllers For temperature sensors with limit value (AC+DC) Codix 564

Block diagram

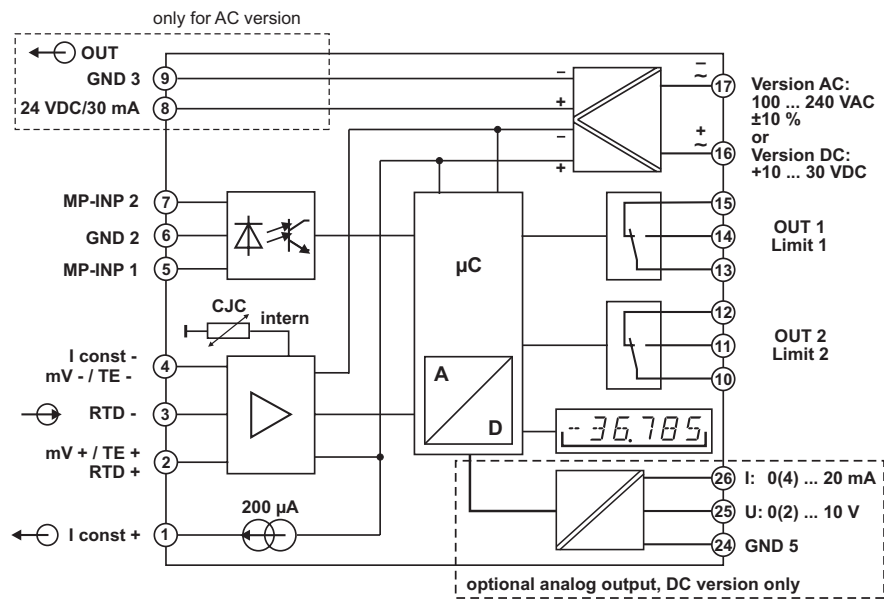

Dimensions

Dimensions in mm [inch]

