

# Slip rings

<b>Three chamber system</b>	<b>Ethernet transmission</b>	<b>SR120</b>
-----------------------------	------------------------------	--------------



In general slip rings are used to transmit power, signals or data, pneumatic and hydraulic, from a stationary to a rotating platform.

The transmission between the stator and rotor takes place via sliding contacts and is extremely reliable.

The slip ring SR120 is ideal for applications requiring high transmission rates. The three chamber system allows parallel transmission of signals, load and data up to 100 Mbit/s.

### Rugged

- Reliable operation in harsh environments.
- Rugged metal housing.
- High protection level IP64.

### Flexible

- Fast and easy installation.
- Modular construction.
- Wide variety of connector and cable connections.

### Reliable with the three chamber system

- Reliable thanks to interference-proof transmission.
- Transmission of Ethernet, signal, load, pneumatics and hydraulics.
- Innovative contact technology, low-maintenance and durable.
- Fieldbus or Ethernet up to 100 Mbit/s.
- UL approval in preparation.

### Application areas for slip rings

Industrial automation, bottling plants, labelling machines, rotary tables, ...

### Order code

for standard versions

**SR120** - **XX** - **XX** - **XX** - **XX** - **X0X2** - **V100**  
Type                      a                      b                      c                      d                      e f g h                      i

#### a Type of mounting

- 01 = flange mounting, rotor connections radial
- 02 = flange mounting, rotor connections axial

#### b Number of Ethernet transmissions

- 00 = none
- 01 = Ethernet transmission up to 100 Mbit/s

#### c Module signal / data channels <sup>1)</sup>

- 00 = none
- 02 = 2 channels
- 04 = 4 channels
- 06 = 6 channels
- C0 = CANopen
- D0 = DeviceNet
- M0 = Modbus
- P0 = Profibus

#### d Module load channels <sup>2)</sup>

- 00 = none
- 02 = 2 x load
- 04 = 4 x load
- 06 = 6 x load
- L3 = 3 x load + ground PE
- L4 = 4 x load + ground PE

#### e Load channels max. load current

- 0 = none
- 1 = 230 V / 16 A
- 2 = 230 V / 25 A
- 3 = 400 V / 10 A
- 4 = 400 V / 20 A

#### f Type of connection

- 0 = cable <sup>3)</sup>

#### g Central lead-through

- 0 = none
- 1 = air connection 1/4"
- 2 = air connection 1/2"
- 3 = air connection 3/8"
- A = central bore, inside diameter 20 mm
- B = central bore, inside diameter 15 mm

#### h Protection rating

- 2 = IP64

#### i Version number (options)

- V100 = without options
- >V100 = options on request, e.g.:
  - > 20 channels
  - other types of mounting
  - other types of connection (cable, connector, ...)
  - hydraulics connection

Connection technology	Order no.
<b>Cordset, pre-assembled</b>	M12 male connector with external thread, 4-pin 2 m [6.56'] PUR cable <b>05.00.6031.4411.002M</b>
<b>Connector, self-assembly (straight)</b>	M12 male connector with external thread, 4-pin <b>05.WASCSY4S</b>
<b>Industrial Ethernet - cable</b>	PUR electronic cable <b>05.00.6031.1111.XXXM <sup>4)</sup></b>

Additional connectors can be found in the connection technology section or in the connection technology area of our website at: [www.kuebler.com/connection\\_technology](http://www.kuebler.com/connection_technology).

1) Additional signal / data channels on request (option)

e.g. C2 = CAN module expansion with 2 additional channels

Connection lines for CAN and signal transmission separated on stator and rotor side.

2) Additional load channels on request (option).

3) Except Ethernet channel (M12 connector).

4) XXXX = cable length in meters (e.g. 10 m = 0010).

# Slip rings

## Three chamber system      Ethernet transmission      SR120

Technical data	
<b>Overall length</b>	dep. on the number of transmission paths
<b>Type of connection</b> (stator and rotor)	load cable 2 m [6.56'] signal / data cable 2 m [6.56'] Ethernet M12 connector 4-pin, D coded
<b>Material pairing</b>	load copper / bronze signal / data silver / precious metal Ethernet silver / precious metal
<b>Voltage/current loading</b>	
load channels	order option 1 230 V AC/DC, max. 16 A, 50/60 Hz order option 2 230 V AC/DC, max. 25 A, 50/60 Hz order option 3 400 V AC/DC, max. 10 A, 50/60 Hz order option 4 400 V AC/DC, max. 20 A, 50/60 Hz
signal channels	48 V AC/DC, max. 2 A
<b>Contact resistance</b>	
load channels	≤ 1 Ohm (dynamic) <sup>1)</sup>
signal / data channels	≤ 0,1 Ohm (silver / precious metal) <sup>2)</sup>
<b>Insulation resistance</b>	10 <sup>3</sup> MOhm, at 500 V DC
<b>Dielectric strength</b>	1000 V eff. (60 sec.)
<b>Speed max. (signal / data channels)</b>	300 min <sup>-1</sup> (depends on installation position and numbers of channels)
<b>Service life (signal / data channels)</b>	typ. 500 million revolutions (at room temperature) depends on installation position

<b>Maintenance cycles</b>	maintenance free (if necessary all 100 million revolutions)
<b>Maintenance</b>	Remove contact abrasion dust – do not use compressed air
<b>Operating temperature</b>	-35° ... +85°C [-31°F ... +185°F]
<b>Protection acc. to EN 60529</b>	max. IP64
<b>Transmission paths</b>	max. 20 (> 20 on request)

Air connection (media lead-through no. 1 - 3)	
<b>Air pressure max.</b>	10 bar (150 psi)
<b>Vacuum max.</b>	7 kPa (2" Hg)
<b>Speed max.</b>	300 min <sup>-1</sup>

Slip rings

### Technology in detail

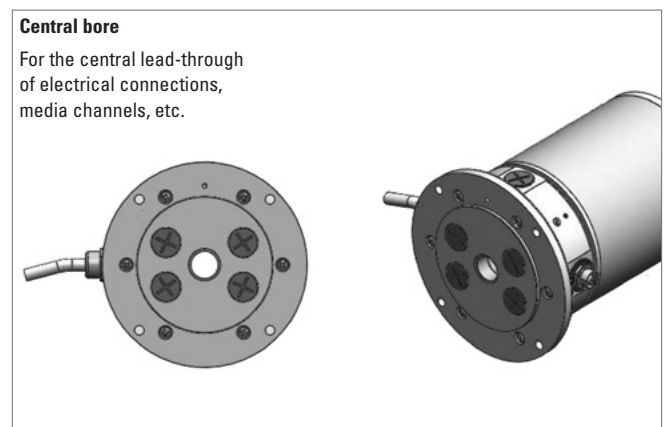
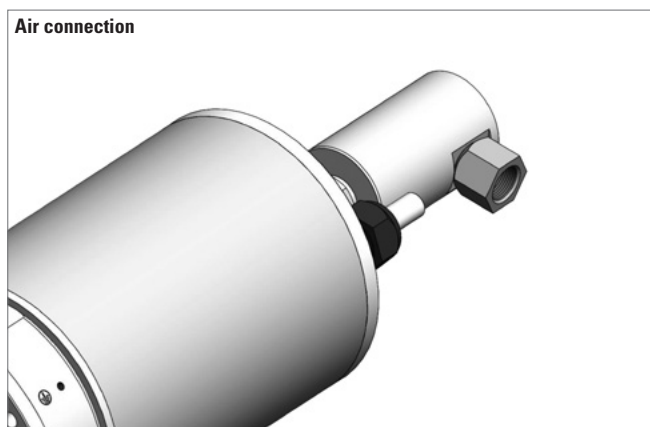
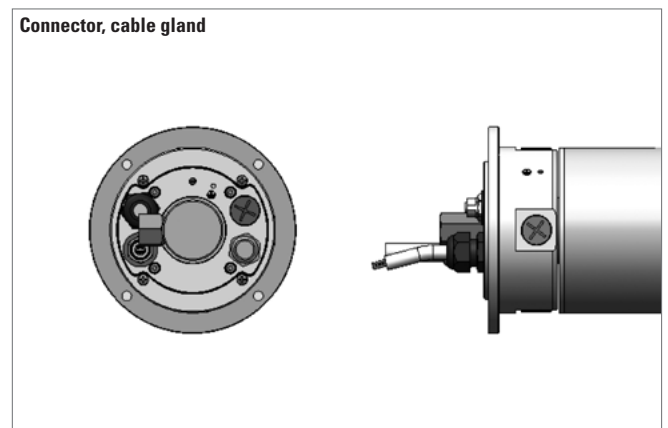
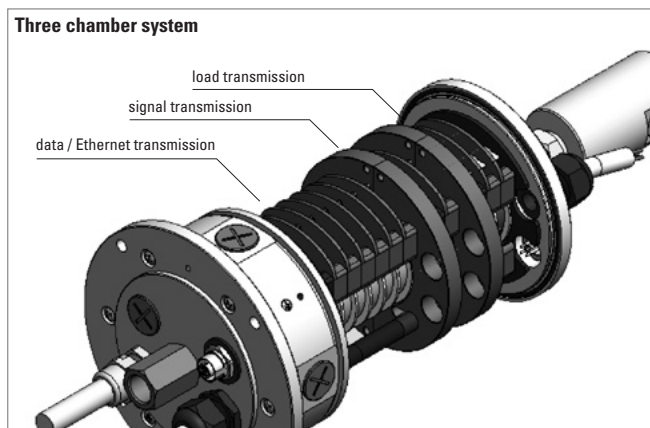

1) Voltage measurement, ambient temperature, DC series connection, ohmic load, min. 4 A test current.  
2) 2-wire resistance measurement, ambient temperature, 6,5-digit digital multimeter or similar, values without testing cable.

# Slip rings

<b>Three chamber system</b>	<b>Ethernet transmission</b>	<b>SR120</b>
-----------------------------	------------------------------	--------------

## Terminal assignment

M12 connector, 4-pin					
Signal:	Transmit data +	Receive data +	Transmit data -	Receive data -	
Abbreviation:	TxD+	RxD+	TxD-	RxD-	
Pin:	1	2	3	4	

## Dimensions

Dimensions in mm [inch]

### Standard version

Example: Type SR120-02-01-02-03-2002-V100

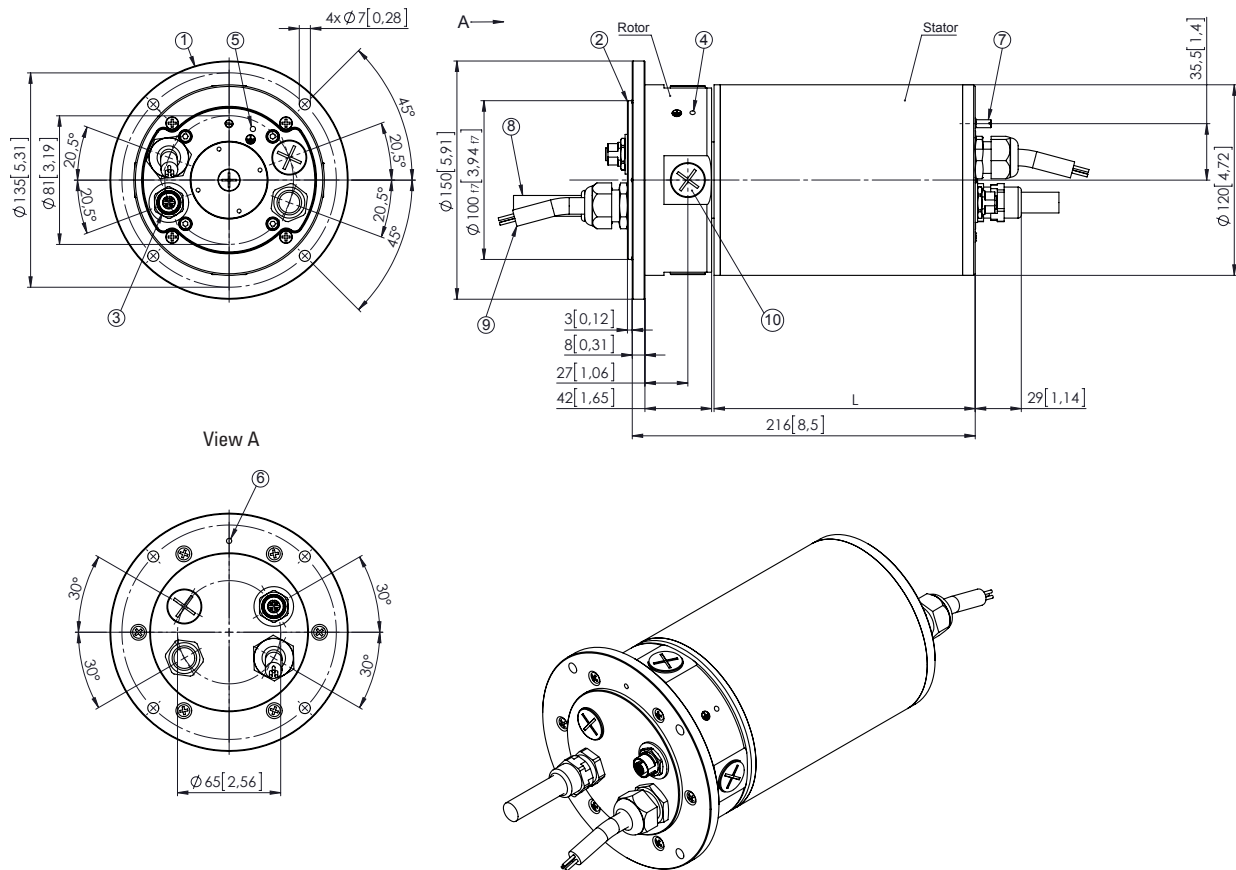

- |  |  |   |
|--|--|---|
| 1 – Mounting flange  | 4 – Grounding PE (optional connectivity) | 8 – 2 m [6.56'] connecting cable for load transmission                      |
| 2 – Centering diameter   | 5 – Grounding PE (optional connectivity) | 9 – 2 m [6.56'] connecting cable for signal transmission                    |
| 3 – M12 female connector (4-pin)<br>Ethernet (data transmission) (D-coded) | 6 – Grounding PE (optional connectivity) | 10 – Blind plug – depending on order code rotor<br>connections exit axially |
|  | 7 – Anti-rotating-pin                    |   |

# Slip rings

**Three chamber system**      **Ethernet transmission**      **SR120**

## Dimensions

Dimensions in mm [inch]

### Version with media lead-through

Example: Type SR120-02-01-02-03-2032-V100

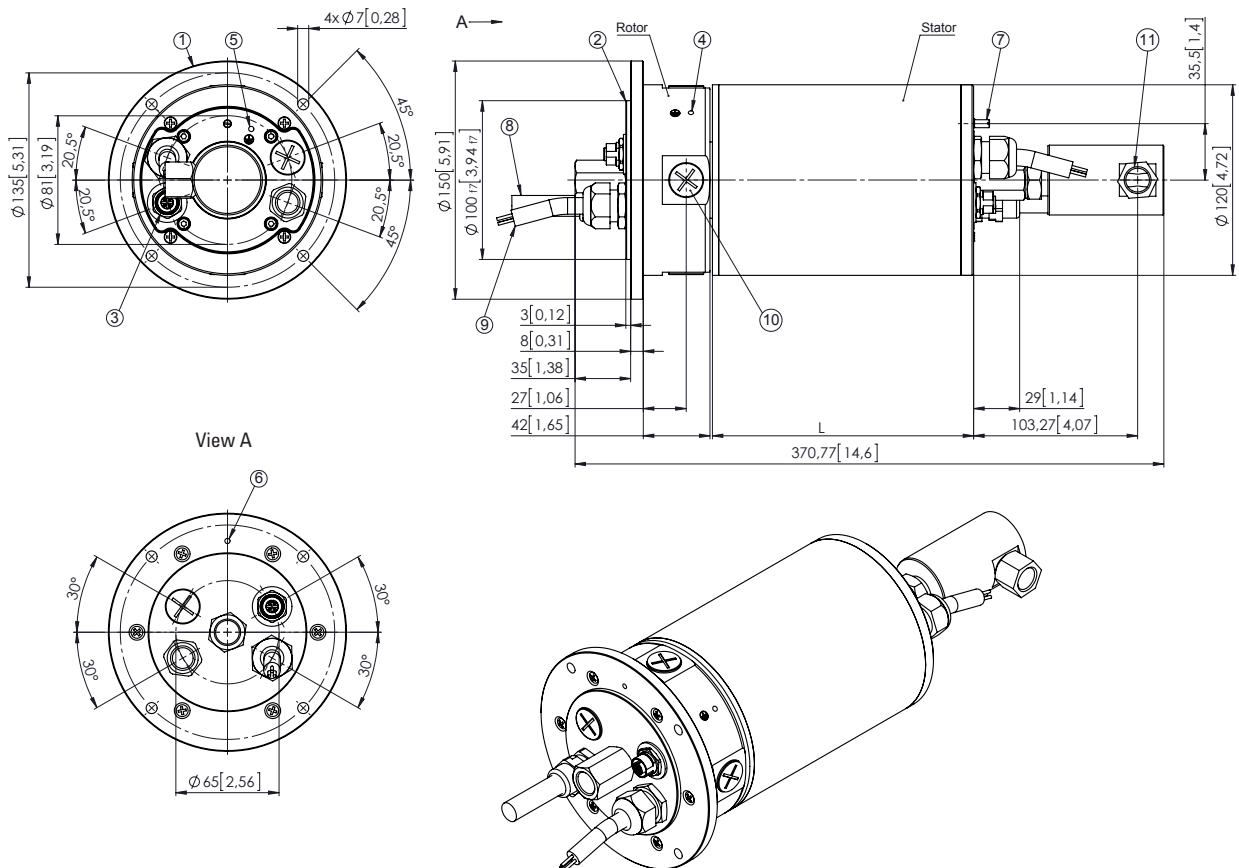

Slip rings

- |  |  |  |
|--|--|--|
| 1 – Mounting flange  | 4 – Grounding PE (optional connectivity) | 8 – 2 m [6.56'] connecting cable for load transmission                                     |
| 2 – Centering diameter   | 5 – Grounding PE (optional connectivity) | 9 – 2 m [6.56'] connecting cable for signal transmission                                   |
| 3 – M12 female connector (4-pin)<br>Ethernet (data transmission) (D-coded) | 6 – Grounding PE (optional connectivity) | 10 – Blind plug – depending on order code<br>connections exit axially                      |
|  | 7 – Anti-rotating-pin                    | 11 – Media lead-through – depending on order code<br>connection thread G 1/2, G 1/4, G 3/8 |