

#### PROPERTIES

##### DESIGN

With clamping collar and a single clamping screw.

Clutch system: spring loaded ball-detent principle. Operable temperature range from -30 to +120° C.

##### AVAILABLE FUNCTION SYSTEMS

- ▶ W = Single position / automatic re-engagement (standard)
- ▶ D = Multi-position / automatic re-engagement

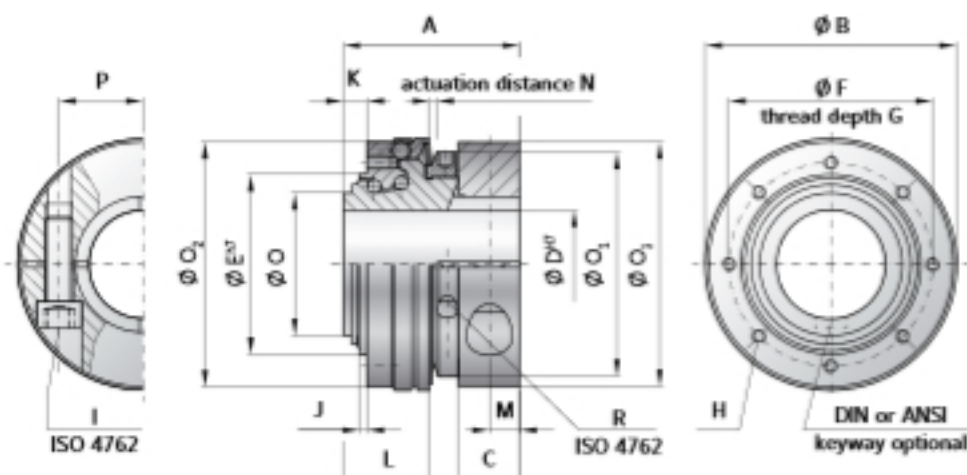

#### MODEL SLN

SIZE			30	60	150	300
Adjustment range* from - to	(Nm)	T <sub>max</sub>	10-35 30-80 40-135	30-80 60-120 100-200	40-100 100-200 150-300	200-350 300-450 400-550 550-700
Overall length	(mm)	A	45	53	63	72
Actuation ring Ø	(mm)	B	63	74	92	118
Clamping fit length	(mm)	C	15	18	22	24
Bore diameter from Ø to Ø H7	(mm)	D	12-30	16-35	19-42	22-60
Pilot diameter h7	(mm)	E	43	53	68	85
Bolt-hole circle diameter ± 0.2	(mm)	F	48	60	75	95
Thread depth +1	(mm)	G	5	6	7	9
Fastening threads		H	8x M4	8x M4	8x M5	8x M6
Screw ISO 4762		I	M6	M8	M10	M12
Tightening torque	(Nm)		15	40	75	130
Centering length -0.2	(mm)	J	2	2	3	3
Distance	(mm)	K	6	7	9	9
Distance to actuation ring edge	(mm)	L	23	26	32	36
Distance	(mm)	M	7.5	9	11	12
Actuation distance	(mm)	N	1.3	1.5	1.8	2
Ø Base element	(mm)	O	35	42	54	70
Ø Adjustment nut	(mm)	O <sub>1</sub>	55	66	82	100
Ø Flange -0.2	(mm)	O <sub>2</sub>	58	72	87	110
Ø Clamp ring	(mm)	O <sub>3</sub>	59	72	90	114
Distance between centers	(mm)	P	21.5	25	33	41
Adjustment nut's clamp screw ISO 4762		R	M3	M3	M3	M4
Tightening torque	(Nm)		2	2	2	4.5
Approx. weight	(kg)		0.3	0.5	0.8	1.5
Approx. moment of inertia at D max	(10 <sup>-4</sup> Kgm <sup>2</sup> )	J <sub>cm</sub>	0.15	0.3	1	3

\*Maximum transmittable torque of the clamping hub depends on the bore diameter / see table below

#### MAXIMUM TRANSMITTABLE TORQUE IN RELATION TO BORE DIAMETER

SIZE	Ø 12	Ø 15	Ø 20	Ø 25	Ø 30	Ø 35	Ø 40	Ø 45	Ø 50	Ø 55	Ø 60
30	30	55	80	110	130						
60		80	120	160	200	220					
150			200	250	300	350	400	450			
300				350	430	510	590	670	750	830	910

Higher torque possible with keyway.