

SK2

WITH CLAMPING HUBS

0.1 - 1,800 Nm



PROPERTIES

MATERIAL

- ▶ **Bellows:** high grade stainless steel
- ▶ **Clutch system:** hardened steel
- ▶ **Clamping hubs:** up to size 80 aluminum, size 150 and up steel

temperature range from -30 to +100° C.

AVAILABLE FUNCTION SYSTEMS

- ▶ **W** = Single position / automatic re-engagement (standard)
- ▶ **D** = Multi-position / automatic re-engagement
- ▶ **G** = Load holding / load blocking
- ▶ **F** = Full disengagement / manual re-engagement

DESIGN

Two clamping hubs with one clamping screw in each. Clutch system: spring loaded ball-detent principle. Operable

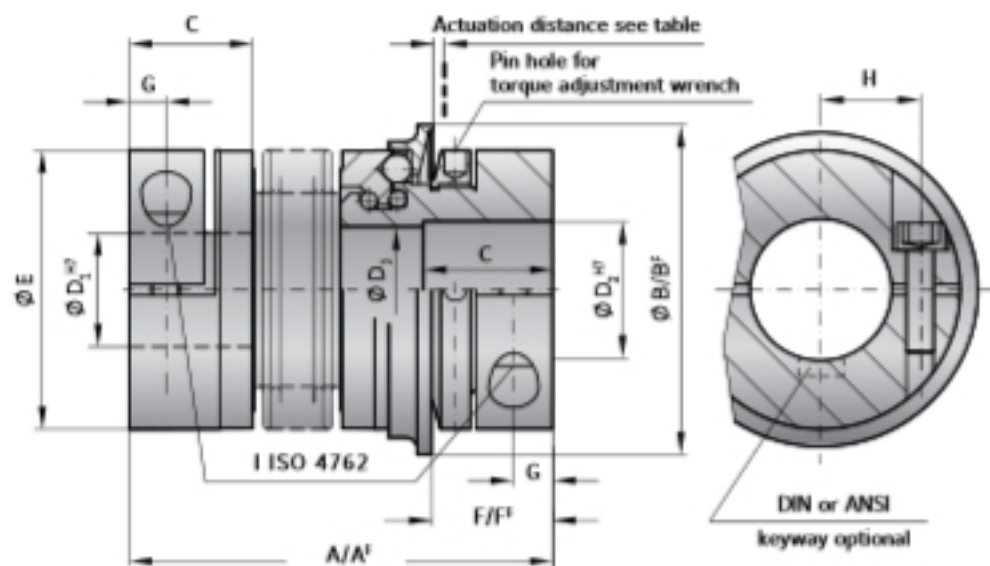

MODEL SK2

SIZE		1.5	2	4.5	10	15	30	60	80	150	200	300	500	800	1500
Adjustment range available from - to (approx. values) (Nm)	T_{set}	0.1-0.6 0.4-1 0.8-1.5	0.2-1.5 or 0.5-2	1-3 or 3-6	2-6 or 4-12	5-10 or 8-20	10-25 or 20-40	10-30 or 25-80	20-70 or 30-90	20-70 or 45-150 80-180	30-90 or 60-160 120-240	100-200 or 150-240 200-320	80-200 or 200-350 300-500	400-650 or 500-800 650-850	650-800 or 700-1200 1000-1800
Adjustment range available from - to (approx. values) ("F" Version) (Nm)	T_{set}	0.3-0.8 or 0.6-1.3	0.2-1 or 0.7-2	2.5-4.5	2-5 or 5-10	7-15	8-20 or 16-30	20-40 or 30-60	20-60 or 40-80	20-60 or 40-80 80-150	80-140 or 130-200	120-180 or 160-300	60-150 or 100-300 250-500	200-400 or 450-800	1000-1250 or 1250-1500
Overall length (mm)	A	42	46 51	57 65	65 74	75 82	87 95	102 112	115 127	116 128 128 140	139 153	163 177	190	223	
Overall length, ("F" Version) (mm)	A'	42	46 51	57 65	65 74	75 82	87 95	102 112	117 129	118 130 131 143	142 156	167 181	201	232	
Actuation ring ϕ (mm)	B	23	29	35	45	55	65	73	92	92	99	120	135	152	174
Actuation ring ϕ , ("F" Version) (mm)	B'	24	32	42	51.5	62	70	83	98	98	117	132	155	177	187
Clamping fit length (mm)	C	11	13	16	16	22	27	31	35	35	40	42	51	48	67
Inside diameter from ϕ to ϕ H7 (mm)	D_1/D_2	3-8*	4-12*	5-14*	6-16*	10-26	12-30	15-32	19-42	19-42	24-45	30-60	35-60	40-75	50-80
Diameter (mm)	D_1	9.1	12.1	14.1	20.1	21.1	24.1	32.1	36.1	36.1	42.1	58.1	60.1	60.1	68.1
Outside diameter of coupling (mm)	E	19	25	32	40	49	55	66	81	81	90	110	123	134	157
Distance (mm)	F	12	13	15	17	19	24	28	31	31	35	35	45	50	63
Distance, ("F" Version) (mm)	F'	11.5	12	14	16	19	22	29	31	30	33	35	43	54	61
Distance (mm)	G	3.5	4	5	5	6.5	7.5	9.5	11	11	12.5	13	17	18	22.5
Distance between centers (mm)	H	6	8	10	15	17	19	23	27	27	31	39	41	2x48	2x55
Screw ISO 4762	I	M2.5	M3	M4	M4	M5	M6	M8	M10	M10	M12	M12	M16	2xM16	2xM20
Tightening torque (Nm)		1	2	4	4.5	8	15	40	50	70	120	130	200	250	470
Approx. weight (kg)		0.047	0.07	0.2	0.3	0.4	0.6	1.0	2.0	2.4	4.0	5.9	9.6	14	21
Moment of inertia (10^{-4} kgm ²)	J_{pol}	0.01	0.01 0.01	0.02 0.02	0.06 0.07	0.10 0.15	0.27 0.32	0.75 0.80	1.80 1.90	2.50 2.80	5.10 5.30	11.5 11.8	22.8 23.0	42.0	83.0
Torsional stiffness (10^3 Nm/rad)	C_t	0.7	1.2 1.3	7 5	9 8	20 15	39 28	76 55	129 85	175 110	191 140	420 350	510 500	780	1304
Lateral \pm (mm)	max. values	0.15	0.15 0.20	0.20 0.25	0.20 0.30	0.15 0.20	0.20 0.25	0.20 0.25	0.20 0.25	0.20 0.25	0.20 0.25	0.30 0.25	0.30 0.35	0.35	0.35
Angular \pm (Degree)		1	1 1.5	1.5 2	1.5 2	1 1.5	1 1.5	1 1.5	1 1.5	1 1.5	1 1.5	2 1.5	2 2	2.5	2.5
Lateral spring stiffness (N/mm)		70	40 30	290 45	280 145	475 137	900 270	1200 420	920 255	1550 435	2040 610	3750 1050	2500 840	2000	3600
Actuation distance (mm)		0.7	0.8	0.8	1.2	1.5	1.5	1.7	1.9	1.9	2.2	2.2	2.2	2.2	3

A', B', L' = Full disengagement / manual re-engagement version (F)

Larger versions available upon request.

* keyway with max. bore only in clamping hub possible.