

EK7

WITH EXPANDING SHAFT

2 - 2,150 Nm



PROPERTIES

FEATURES

- ▶ for hollow shaft mounting
- ▶ short overall length
- ▶ solution for mismatched bore / shaft diameters

MATERIAL

- ▶ **Hubs:** up to size 450 high strength aluminum; size 800 steel
- ▶ **Expanding shaft hub:** steel

- ▶ **Elastomer:** wear resistant thermally stable TPU

DESIGN

One concentrically machined hub with clamping screw and curved jaws. One concentrically machined hub with expanding shaft system and curved jaws.

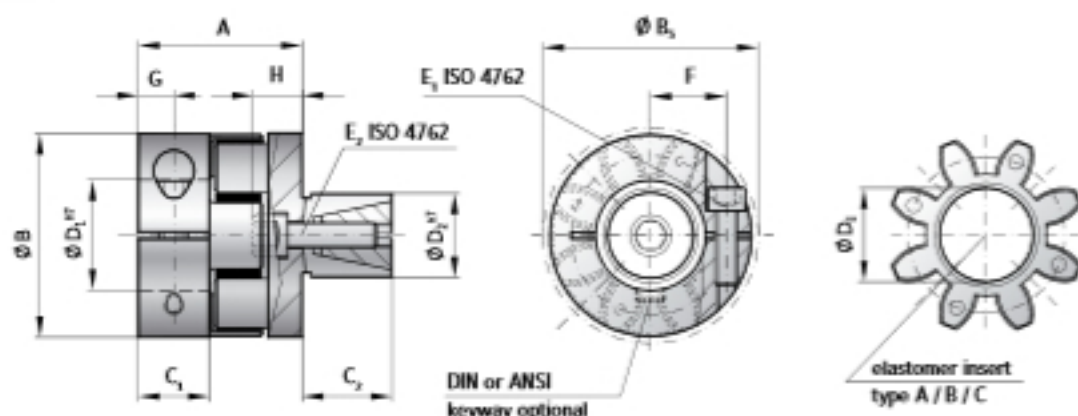

MODEL EK7

SIZE	5			10			20			60			150			300			450			800		
Type (Elastomer insert)	A	B	C	A	B	C	A	B	C	A	B	C	A	B	C	A	B	C	A	B	C	A	B	C
Rated torque (Nm) T_{ex}	9	12	2	12.5	16	4	17	21	6	60	75	20	160	200	42	325	405	84	530	660	95	950	1100	240
Max. torque* (Nm) T_{lim}	18	24	4	25	32	6	34	42	12	120	150	35	320	400	85	650	810	170	1060	1350	190	1900	2150	400
Overall length (mm) A	22			28			40			46			51			68			76			94		
Outside diameter (mm) B	25			32			42			56			66.5			82			102			136.5		
Outside diameter with screw head (mm) B_1	25			32			44.5			57			68			85			105			139		
Mounting length (mm) C_1	8			10.3			17			20			21			31			34			46		
Mounting length (mm) C_2	12			20			25			27			32			45			55			60		
Inside diameter range H7 (mm) D_1	4 - 12.7			5 - 16			8 - 25			12 - 32			19 - 36			20 - 45			28 - 60			35 - 80		
Outside diameter range h7 (mm) D_2	10 - 16			13 - 25			14 - 30			23 - 38			26 - 42			38 - 60			42 - 70			42 - 80		
Inside diameter of elastomer (mm) D_3	10.2			14.2			19.2			26.2			29.2			36.2			46.2			60.5		
Clamping screw (ISO 4762) E_1	M3			M4			M5			M6			M8			M10			M12			M16		
Tightening torque (Nm)	2			4			8			15			35			70			120			290		
Clamping screw (ISO 4762) E_2	M4			M5			M6			M8			M10			M12			M16			M16		
Tightening torque (Nm)	4			9			12			32			60			110			240			300		
Distance between centers (mm) F	8			10.5			15.5			21			24			29			38			50.5		
Distance (mm) G	4			5			8.5			10			11			15			17.5			23		
Length (mm) H	7			7			10			11			16			20			27			27		
Moment of inertia D_1 (10^{-2} kgm ²) J_1	0.002			0.003			0.01			0.04			0.08			0.3			0.66			8		
Moment of inertia D_2 (10^{-2} kgm ²) J_2	0.002			0.01			0.04			0.1			0.2			1			2.6			9		
Approx. weight (kg)	0.04			0.05			0.12			0.3			0.5			0.9			1.5			7.6		
Speed standard (min ⁻¹)	15,000			13,000			12,500			11,000			10,000			9,000			8,000			4,000		
Speed balanced (10^4 min ⁻¹)	57	65	43	53	63	40	45	60	35	31	31	25	22	26	18	22	26	16	16	17	12	13	13	8

For information on shaft misalignment, torsional stiffness, and other details about the elastomer inserts see pages 72 + 73.

* Maximum transmittable torque of the clamping hub depends on the bore diameter (see EKL on page 68).

ORDERING EXAMPLE	EK7	20	A	24	19.05	XX
Model	●					
Size		●				
Elastomer insert type			●			
Bore D1 H7				●		
Expanding shaft D2 h7					●	
Special designation only (e.g. special bore tolerance).						

For custom features place an XX at the end of the part number and describe the special requirements (e.g. EK7 / 20 / A / 24 / 19.05 / XX; XX=stainless steel)