



PROPERTIES

FEATURES

- ▶ for high temperatures and aggressive media
- ▶ compact design
- ▶ welded version

MATERIAL

- ▶ **Bellows:** high grade stainless steel
- ▶ **Hubs:** high grade stainless steel

- ▶ **Screws:** Grade 12.9 Geomet coated (alternate materials on request)

DESIGN

Two clamping hubs concentrically mounted to flexible bellows. Brief overloads of up to 1.5x the rated torque are acceptable. From -40° to +300°C operating temperature.

Optional: self-opening clamp system to open the bore during installation and removal by backing out the clamping screw.

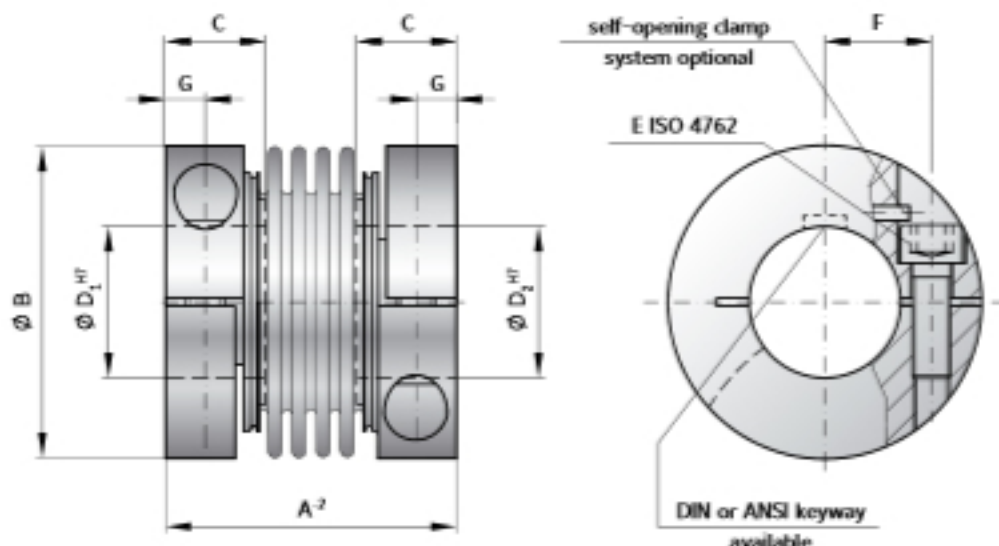

MODEL BKS

SIZE			15	30	60	150	300	500
Rated torque (Nm)	T_{en}		15	30	60	150	300	500
Overall length (mm)	A^2		45	52	66	76	89	95
Outside diameter (mm)	B		49	56	66	82	110	123
Fit length (mm)	C		17	20	24	30	34	35
Inside diameter* possible from ϕ to ϕ H7 (mm)	D_1/D_2		12-28	14-32	16-35	19-42	24-60	32-75
Fastening screw ISO 4762			M5	M6	M8	M10	M12	M12
Tightening torque of the fastening screw (Nm)	E		8	15	40	75	120	125
Distance between centerlines (mm)	F		17.5	20	23	27	39	45
Distance (mm)	G		6	7.5	9.5	11	13	13
Moment of inertia (10^{-3} kgm ²)	J_{ges}		0.1	0.2	0.53	1.5	5.5	8.1
Approximate weight (kg)			0.27	0.42	0.78	1.5	2.9	3.5
Torsional stiffness (10^3 Nm/rad)	C_t		23	31	72	141	157	290
Axial \pm (mm)	Max. values		1	1	1.5	2	2	2.5
Lateral \pm (mm)			0.2	0.2	0.2	0.2	0.2	0.2
Angular \pm (degree)			1	1	1	1	1	1
Axial spring stiffness (N/mm)	C_a		30	50	67	77	112	72
Lateral spring stiffness (N/mm)	C_l		315	366	679	960	2940	2200
Speed max. with balancing (min ⁻¹)			60,000	50,500	50,000	40,500	40,000	30,000

* Smaller bore diameter available at reduced torque capacity

ORDERING EXAMPLE	BKS	15	20	19.05	XX
Model	●				
Size		●			
Bore D1 H7			●		
Bore D2 H7				●	

Special designation only (e.g. special bore tolerance).

For custom features place an XX at the end of the part number and describe the special requirements (e.g. BKS / 15 / 20 / 19.05 / XX; XX-finely balanced for 25,000 rpm)